



# Load Interconnection Guide

AMERICAN TRANSMISSION COMPANY

# Load Interconnection Guide

*(An ATC Business Practice)*

---

Revision 2.0  
December 30, 2011

American Transmission Company  
W234 N2000 Ridgeview Pwky. Court  
Waukesha, WI 53188-1022

**A**merican Transmission Company (ATC) plans, constructs, owns, operates and maintains the high-voltage electric transmission system (69 kV and above) to provide adequate and reliable transmission of electric power in portions of Wisconsin, Michigan, Minnesota and Illinois. ATC is a member of the Midwest Independent Transmission System Operator, Inc. (MISO) regional transmission organization, and provides nondiscriminatory service to all customers, supporting effective competition in energy markets without favoring any market participant. ATC owns approximately 9,400 miles of transmission lines and more than 500 substations. ATC presently maintains more than 700 load interconnections with municipalities, cooperatives, and investor-owned utilities (Customers). For more information about ATC, visit our Web site at [www.atcllc.com](http://www.atcllc.com).

In general, ATC accommodates a Customer's new or modified load interconnections according to the requirements of a Distribution – Transmission Interconnection Agreement (D-T IA) between ATC and the Customer.<sup>1</sup> ATC will collaborate with the Customer in the development and implementation of the appropriate interconnection solution in response to the Customer's requested need. It is important to note that ATC provides no retail services. The direct interconnection of retail customers to ATC's transmission facilities is governed in part by requirements of the local distribution company or Customer in whose service territory the interconnection is requested.

The Customer is directed to ATC's Web site ([www.atcllc.com/ICS1.shtml](http://www.atcllc.com/ICS1.shtml)) for formal submittal of a load interconnection request for each of the following types of projects:

- 1 New load interconnections or,
- 2 Modifications to existing load interconnection facilities.

Any questions or requests for additional information concerning load interconnections to the ATC Transmission System should be directed to:

[T-DLIRFS@atcllc.com](mailto:T-DLIRFS@atcllc.com)  
ATC Interconnection Services  
**262-506-6700**

---

<sup>1</sup> It is important to note that the phrase "load interconnection" is synonymous to "distribution-transmission interconnection." Capitalized Terms not defined in this Load Interconnection Guide have the meaning set forth in Attachment FF-ATCLLC of the Open Access Transmission, Energy and Operating Reserve Markets Tariff (ASM Tariff).

# Table of Contents

1	Introduction	2
1.1	Purpose	2
1.2	Legal and Regulatory Requirements	2
2	Load Interconnection Process	3
2.1	Process Initiation	3
2.2	Project Development	7
2.3	Project Implementation	8
3	Interconnection Facility Requirements	10
3.1	Overview	10
3.2	ATC and Customer Responsibility	11
3.3	Procedures for Coordinated Joint Studies of New Facilities and Their Impacts on the Interconnected Transmission Systems	12
3.4	Procedures for Notification of New or Modified Facilities to Others (Those Responsible for the Reliability of the Interconnected Transmission Systems) as soon as Feasible	12
3.5	Design of Common Facilities	12
3.6	Interconnection Configuration	13
3.7	Voltage Level and MW and MVAR Capacity or Demand at the Point of Interconnection	16
3.8	Breaker Duty and Surge Protection	18
3.9	System Protection and Coordination	18
3.10	Metering and Telecommunications	22
3.11	Grounding and Safety Issues	22
3.12	Insulation and Insulation Coordination (Basic Impulse Insulation Level)	23
3.13	Voltage, Reactive Power, and Power Factor Control	23

3.14	Power Quality Impacts	24
3.15	Substation Equipment Ratings	25
3.16	Synchronizing of Facilities	26
3.17	Maintenance Coordination	26
3.18	Operational Issues (Abnormal Frequency and Voltages)	27
3.19	Inspection Requirements for Existing or New Facilities	27
3.20	Communications and Procedures During Normal and Emergency Operating Conditions	28
3.21	Transformers	29
3.22	Physical Design Guidelines	33
3.23	References	35
	Revision History	37
	Revision Information	37

# 1 Introduction

## 1.1 Purpose

This Load Interconnection Guide is intended to be a single resource for a Customer working with ATC on a new or modified load interconnection. ATC is committed to working collaboratively with the Customer to effectively plan, develop and implement a safe and reliable new and/or modified load interconnection. This document provides ATC's minimum requirements and guidance to enable development and completion of load interconnections that consistently satisfy the needs of both ATC and its Customers.

This guide generally applies to proposed new load interconnections. ATC will work with the Customer to apply this guide to modifications of an existing interconnection as appropriate, but also while respecting previous interconnection requirements, limitations, and other factors on a case-specific basis. This Guide may also apply to new load interconnections associated with the provision of auxiliary power to generation facilities when the auxiliary power interconnection facilities are a separate interconnection to the ATC Transmission System.

## 1.2 Legal and Regulatory Requirements

### 1.2.1 FERC

Throughout the interconnection process, ATC adheres to the FERC Standards of Conduct<sup>2</sup> as well as the rules relating to critical energy infrastructure information (CEII).

### 1.2.2 State

The states in which ATC operates have their own requirements for siting and construction. This guide is not intended to describe those requirements. The Customer will be responsible for compliance with the specific state requirements and processes. Further information regarding these requirements and processes is available from the pertinent state regulatory agency:

- Public Service Commission of Wisconsin - <http://www.psc.wi.gov/>
- Michigan Public Service Commission - <http://www.michigan.gov/mpsc/>
- Minnesota Public Utilities Commission - <http://www.puc.state.mn.us/>
- Illinois Commerce Commission - <http://www.icc.illinois.gov/>

### 1.2.3 NERC

ATC is registered as a Transmission Owner, Transmission Operator, Transmission Planner, and Planning Authority with both the Midwest Reliability Organization (MRO) and ReliabilityFirst Corporation (RFC) under the requirements of the electric reliability organization, the North American Electric Reliability Corporation (NERC).

---

<sup>2</sup> Order No. 888, 61 FR 21540 (May 10, 1996)

## 2 Load Interconnection Process

This section describes the process that ATC will follow in working with the Customer on a Load Interconnection project. See Appendix B for a high level process overview diagram. ATC works with its Customers to accommodate all requests for load interconnections utilizing the concept of Best Value Planning (BVP)<sup>3</sup>. The BVP process collaboratively establishes a consistent means of assessing an interconnection project that considers various project alternatives; including their costs, as well as issues relating to system performance, construction, maintenance, environmental impacts and regulatory requirements in relation to the requested in-service date. *See Also*, Attachment FF-ATCLLC of the MISO FERC Electric Tariff. Section 2.2 of this document further describes the Best Value Planning process.

### 2.1 Process Initiation

As part of ATC's ongoing planning process, ATC maintains close working relationships existing interconnected Customers in order for both parties to best understand both ATC and the Customer's present and future needs. ATC's planning processes and mechanisms are formally filed at FERC as part of the MISO FERC Electric Tariff.<sup>4</sup>

ATC encourages Customers to share their knowledge of proposed interconnections and load forecasts as soon as possible and especially through regular interaction and meetings with ATC. However, ATC will formally develop a potential new or modified load interconnection only after the Customer submits a Load Interconnection Request Form (LIRF). Upon submittal of a LIRF, ATC will post updates on the status of the load interconnection project on ATC's Load Interconnection Queue<sup>5</sup> when appropriate, recognizing at times that certain projects may have a need for confidential treatment.

Additionally, all existing ATC Customers are required to annually provide ATC with their respective 10-year load forecasts<sup>6</sup> that reflect expected load growth, modified and proposed new load interconnections to be used in the Ten Year Assessment. ATC administers these potential modified or new interconnections reflected in the load forecasts via its Load Interconnection Queue and includes all proposed interconnection projects that have completed the BPV process in ATC's annual system planning used for the 10-Year Assessment.

#### 2.1.1 Load Interconnection Request

The first step in more specifically working with ATC to develop a new load interconnection requires the Customer to submit a completed LIRF to ATC. An example of the LIRF template is included in Appendix D.

##### 2.1.1.1 Scenarios Requiring a LIRF Submittal

The Customer should submit a LIRF to ATC for any additions or modifications to the distribution system that may be reasonably anticipated to have a potential impact on the Transmission System, including the scenarios shown in Table 1.

---

<sup>3</sup> See BVP definition in Appendix A.1

<sup>4</sup> See Attachment FF-ATCLLC of the MISO FERC Electric Tariff <https://www.midwestiso.org/Library/Tariff/Pages/Tariff.aspx>.

<sup>5</sup> See <http://www.atcllc.com/O.shtml>

<sup>6</sup> See <http://www.atc10yearplan.com/> for a complete description of the ATC Planning Ten Year Assessment.

<b>Table 1: Scenarios Requiring LIRF Submittal</b>		
1	<b>New Distribution Interconnections</b>	New interconnections made via either a new or existing substation.
2	<b>Modifications to Existing Distribution Interconnections</b>	Modification of an existing load interconnection (e.g. replacement or addition of an interconnection transformer, capacitors, high-side interrupting device ,etc.).
3	<b>Un-forecasted Load</b>	The addition of any load not included in the Customer’s last 10-year load forecast to ATC.
4	<b>Distribution-Connected Generation (DCG)</b>	Addition of (or change to) any generating capacity interconnected to a distribution system that’s part of an existing load interconnection where the aggregate DCG capacity is >1 MW.
5	<b>Power Quality</b>	Addition or modification of any loads or equipment that may affect power quality.
6	<b>Reliability Needs – Customer Request to Improve Interconnection Performance</b>	Customer requests ATC review transmission service reliability at the Point of Interconnection.

2.1.1.2 Timing of a LIRF Submittal

To enable ATC to meet the needs of the Customer, a LIRF must be received sufficiently in advance of the Customer’s requested in-service date for the new or modified load interconnection. This will allow sufficient time for the following:

- Effective BVP,
- Satisfaction of any necessary regulatory requirements and/or permitting,
- Complete design of necessary facilities,
- Order of long-lead time materials, and
- Safe and effective construction.

However, ATC is also mindful of the possibility of being counterproductive if a LIRF is submitted prematurely and before the Customer can commit firmer to certain project details. Therefore, ATC provides the following guidance for the Customer to consider with respect to when to submit a LIRF. Ultimately, as part of Best Value Planning, ATC and the Customer will develop a mutually agreeable schedule for meeting both parties’ needs with respect to the project service date.

The following represent typical schedule requirements of ATC's project development and implementation process. Ultimately the ATC and Customer implementation team will establish a project-specific schedule that may deviate from the timelines noted below based upon project-specific details.

1. **Best Value Planning (6-18 months):**

BVP between ATC and the Customer can typically take anywhere from 6 to 18 months, dependent upon extent of anticipated scope of work for both parties. At the outset of BVP, ATC and the Customer will agree on a specific development/BVP schedule.

2. **Construction Lead Time (18-60 months):**

a. **18 months**

Construction (after receipt of a fully executed PCA) will take 18 months for load interconnections (any voltage) requiring transmission line extensions of less than 500 feet.

b. **24 months**

- i. Construction (after receipt of a fully executed PCA) will take 24 months for load interconnections at voltages greater than 100 kV with transmission line extensions of 500 feet or greater, but less than 1 mile.
- ii. Construction (after receipt of a fully executed PCA) will take 24 months for load interconnections at voltages less than 100 kV with transmission line extensions up to one mile.

c. **36-54 months**

Construction (after receipt of a fully executed PCA) will take 36-54 months for load interconnections requiring transmission line extensions greater than 1 mile at any transmission voltage.

d. **54-60 months**

Construction (after receipt of a fully executed PCA) will take 54-60 months for load interconnections that potentially involve gas insulated substations, underground transmission, other major Transmission System reinforcements, or a Certificate of Public Convenience and Necessity (CPCN).

2.1.1.3 LIRF Receipt Notice

Within 10 business days of the receipt of a LIRF, ATC will acknowledge the receipt of the LIRF with written communication back to the Customer (typically via e-mail) and, indicate whether the LIRF is complete or if additional information is required. If ATC indicates that the LIRF is not complete, ATC still needs certain information from the Customer in order to cross-functionally and effectively conduct its initial cross-functional evaluation and prepare for planning analyses.

ATC will typically respond to the Customer that a LIRF is complete when the information provided in Table 2 has been received.

<b>Table 2: LIRF Information Required in order to be “Complete”</b>	
1	<b>Requestor Information</b> – contact information for the Customer
2	<b>Load Interconnection Information</b> - substation location and load characteristics
3	<b>10-Year Load Forecast</b> - even if only to indicate that the last forecast is still accurate
4	<b>One-line Diagram</b> – required for modified load interconnections, not necessarily required for new load interconnections (pending development during BVP)
5	<b>Site Map</b> - prospective geographic/physical location(s), especially for a new substation or expansion of an existing substation

ATC can only effectively coordinate with the Customer on a schedule to meet a requested in-service date after **all** information listed above has been included in a LIRF. If all required information is not available at the time the LIRF is submitted, the Customer should contact ATC as soon as possible to jointly determine what developmental work can be performed until the missing information becomes available.

2.1.1.4 Notification of Initial LIRF Review

Within 20 business days of the LIRF being deemed complete, ATC will communicate to the Customer one of the following:

1. ATC’s initial assessment indicates that there are minimal or no anticipated ATC’s network Transmission System or Interconnection Facilities upgrades necessary for ATC to accommodate the proposed new or modified load interconnection.
2. ATC’s initial assessment indicates that it is likely that upgrades to ATC’s network Transmission System and/or Interconnection Facilities will be required to accommodate the proposed new or modified load interconnection. ATC will also seek a collaborative Scoping Meeting with the Customer to determine a schedule for Best Value Planning (BVP).

### 2.1.1.5 LIRF Revisions

If the Customer makes changes to the project that result in changes to LIRF information (e.g. a delay in in-service date, scope of work revision, load forecast changes, etc.), ATC requests that the Customer submit a revised LIRF to ATC to enable project development and/or implementation to continue. ATC will process the LIRF in a manner similar to the original LIRF submittal. If the only change is a change in in-service date, written communication, such as email, is adequate. Should the project change after a PCA is signed, a revised or amended PCA will also be required.

### 2.1.2 Un-Forecasted Load Interconnection Requests

In developing load interconnection requests related to un-forecasted load, ATC and the Customer will collaborate to assess the preliminary best value interconnection solution. This collaboration may include preliminary feasibility and/or system impact studies by ATC relating to the un-forecasted load interconnection request given that the proposed load interconnection request has not been accounted for in the annual 10-year load forecast. The preliminary feasibility and/or system impact studies help to determine if the addition of the un-forecasted load would have an adverse impact on the ATC Transmission System. Un-forecasted load interconnection requests may cause ATC and its Customer to consider additional issues such as aggressive in-service dates, significant transmission system upgrades outside of the load interconnection, regulatory timelines, and outage schedules while jointly developing a solution to satisfy the un-forecasted load interconnection request.

Once a LIRF is submitted, ATC will typically perform formal studies related to a *single* preferred interconnection location (as mutually agreed to by ATC and the Customer). Should the Customer request the formal study of additional interconnection locations related to the same load interconnection need, ATC reserves the right to charge the cost of such additional studies to the Customer in accordance with ATC's Elective Load Interconnection Facilities Business Practice. The Customer will be responsible to pay for the estimated cost of any additional studies prior to ATC beginning the additional study work.

## 2.2 Project Development

ATC and the Customer will employ Best Value Planning (BVP) in order to determine the most effective solution to meet the Customer's load interconnection request.

BVP describes ATC and the Customer's collaborative development of the requested load interconnection project and determination of the best value solution. Steps within the BVP process include:

1. ATC and the Customer meet to agree on the study schedule, study milestones, needs analysis, alternatives (both transmission and distribution) to consider, the forms of communication to be used while working together, and formal documentation.
2. The Customer documents needs / project justification and its part of a draft BVP matrix including alternatives considered; all in support of the Customer's analysis.
3. ATC documents needs / project justification and its part of a draft BVP matrix including alternatives considered; all in support of ATC's analysis.
4. ATC and the Customer complete a formal BVP report.
5. ATC and the Customer acquire management approvals as required before moving the project formally to implementation.

ATC and the Customer will formally document their BVP collaboration and conclusions in a Best Value Plan Project Scoping Report<sup>7</sup>.

BVP takes into account such factors as:

1. Customer justification or need drivers behind the requested load interconnection,
2. Distribution and transmission system performance assessment including; power flow impact (voltage and thermal limitations), short circuit changes, protection/coordination concerns, operational concerns/limitations and asset management/maintenance concerns.
3. ATC stakeholder impact.
4. Construction as well as operating costs (for both transmission and distribution facilities),
5. Environmental issues,
6. Siting requirements, including land acquisition and permits, and
7. Ongoing operations and maintenance considerations, including reliability impacts on the transmission system.

To facilitate consistent analysis, review, documentation, and resource allocation for a given load interconnection project; Appendix C describes four different reporting levels of Best Value Planning activities and the responsibilities of both ATC and its Customer. The complexity of the assessment associated with the BVP Project Scoping Report is dependent on the size and cost of the proposed load interconnection project. Once ATC and its Customer determines the best value solution to meet ATC and the Customer's needs, ATC and the Customer prepare the Best Value Plan that sets forth the solution to meet the Customer's load interconnection request. Once the BVP is completed, the next implementation step is to develop the Project Commitment Agreement (PCA) that sets forth for both parties the scope of construction activities and the proposed construction schedule in order to construct the facilities necessary to interconnect the new load or modify the existing load interconnection facilities. For more information the process included in BVP, please refer to the BVP white paper located at <http://www.atcllc.com/O.shtml>. Please also refer to Attachment FF-ATCLLC of the MISO FERC Electric Tariff for additional information.

## 2.3 Project Implementation

Once ATC and the Customer agree on the best value solution and formally publish a BVP report, as appropriate, ATC will provide the Customer with a Project Commitment Agreement (PCA) for execution. The PCA is the formal agreement between ATC and the Customer for construction of the best value solution and a commitment by both parties to implement it. The PCA documents include: 1.) the scope of work to be performed, 2.) the work cost estimates and 3.) an in-service date agreed upon by both parties. The PCA is expected to be returned within 60 business days (or by a date mutually agreeable to both parties).

---

<sup>7</sup> The collaborative review / analysis and Best Value Plan documentation of an interconnection project is governed in part by NERC Standard FAC-002-0 requirements R1.1, R1.2, R1.3, R1.4 and R1.5 and the requirements of ATC's Local Planning under Attachment FF-ATCLLC of the Midwest ISO Tariff. Both ATC and the Customer are required to retain the documentation of the reliability impact of the new facilities in accordance with NERC Standard FAC-002-0 requirement R.2. Additionally, it is required that the Customer ensure that the load associated with the interconnection project is included within the metered boundaries of a Balancing Authority in accordance with NERC Standard BAL-005-0 requirement R1.3.

2.3.1 Project Commitment Agreement (PCA)

At a minimum, the PCA will typically include the items in Table 3.

<b>Table 3: Required PCA Contents</b>		
1	<b>BVP Project Scoping Report</b>	Provides the reasoning that supports the decision for the facilities to be constructed.
2	<b>Non-Typical Planning Studies</b>	Indication of any remaining studies, aside from the typical planning studies. (Examples may include power quality studies, special protection assessments, etc.)
3	<b>Project Schedule</b>	An estimated project schedule, including a timeline for any necessary regulatory approvals and the expected completion date of the project.
4	<b>High-Level Scope of Work</b>	Including a one-line diagram, project location or map.
5	<b>Applicable Business Practices</b>	Indication of other applicable ATC Business Practices associated with the project.

As stated in Section 2.2 above, the PCA is the formal agreement between ATC and the Customer summarizing the BVP assessment and creating a commitment by both parties to implement it. The PCA documents: 1.) the scope of work to be performed, 2.) the work cost estimates, and 3.) establishes an in-service date that is agreed upon by both parties.

An example of the PCA template is included in Appendix E.

2.3.2 Distribution - Transmission Interconnection Agreement

ATC requires execution of a Distribution – Transmission Interconnection Agreement (D-T IA) before ATC will commence with any regulatory proceedings (if applicable) or otherwise begin design engineering on any project associated with a load interconnection request. If the request is from a Customer that has an existing Distribution – Transmission Interconnection Agreement, the new interconnection will be included in the periodically updated exhibits to the D-T IA.

2.3.3 Regulatory Approvals

In the event that the load interconnection request requires regulatory approvals or filings, ATC and the Customer shall cooperate in seeking any regulatory or other approvals by providing the necessary information and participating in any regulatory proceeding or process to demonstrate need for the project, if requested to do so by either ATC or the Customer.

Examples of regulatory approvals or filings include, but are not limited to:

State Public Service Commissions for<sup>8</sup>:

- Construction Authorization filings,
- Certificates of Public Convenience and Necessity filings,
- Affiliated Interest filings

Federal Energy Regulatory Commission for:

- D-T IA filings

NERC (including Midwest Reliability Organization and ReliabilityFirst Corporation) for:

- Reliability filings / reports associated with interconnection facilities at voltages greater than or equal to 100 kV.

Please note; NERC compliance is the responsibility of both ATC and the Customer. Under NERC requirements, ATC is a registered:

- Transmission Owner
- Transmission Operator
- Planning Authority,
- and Transmission Planner.

**IMPORTANT NOTE:** ATC does not assume any NERC reliability responsibilities aside from those listed above. The D-T IA between ATC and its Customers is not a delegation of, nor the transfer of either party's NERC functional responsibilities from one party to the other.

Additional requirements applicable to both parties' substations are set forth in state electrical and administrative codes. ATC should be consulted on matters relative to the guidelines and requirements contained in this guide, but Customers are advised to consult directly with appropriate code enforcement authorities for matters that pertain to requirements of other applicable governing codes and/or with the specific requirements set forth in contracts concluded with ATC. Likewise, the regulatory filings listed above are for ATC requirements only, the Customer may have regulatory filings that may also be needed as determined by the Customer.

#### 2.3.4 ATC's relationship to the wholesale electric market

ATC owns, operates and plans the transmission system over which MISO provides transmission service in conjunction with its MISO FERC Electric Tariff. ATC is not a Market Participant in the MISO Energy and Operating Reserve Markets.

## 3 Interconnection Facility Requirements

### 3.1 Overview

These design guidelines apply predominantly to new load interconnections and modifications to existing interconnections. ATC will work with the Customer to apply these guidelines as appropriate and feasible for modifications to existing load interconnections. Some proposed load interconnections may also require necessary network upgrades to ATC's Transmission System, beyond the interconnection facilities themselves. This guide does not govern those additional ATC Transmission System modifications that may be required. Any upgrades

---

<sup>8</sup> Note: Regulatory requirements vary from state to state and need to be coordinated between ATC and its Customer for a given project.

needed to the ATC transmission system will be identified within the BVP Project Scoping Report and used when assessing alternatives.

By following the process guidelines presented in the previous section of this document, ATC and its Customers work together to develop an interconnection project design in response to a Customer's interconnection request. This section of the document offers an overview of technical design guidelines to assist ATC and its Customers when developing a project solution for a load interconnection request.

It is important to note that ATC design standards apply to ATC Transmission System facilities and that the Customer's design standards apply to the Customer's facilities unless otherwise specifically noted in the following sections.

In the event that such ATC design guides, standards or specifications do not address a particular item or issue, ATC requires that the Customer and ATC agree on the use of nationally-recognized standards, guides or specifications to ensure that the Customer's Interconnection Facilities are designed in accordance with Good Utility Practice and any applicable Mandatory Reliability Standards. In the event that there is a conflict between any mandatory standard, guide or specification and ATC's design guides, standards and material/construction specifications, the more restrictive design guides, standards and specifications will apply.

## 3.2 ATC and Customer Responsibility

The requirements in this guide are part of the requirements necessary to protect ATC's transmission facilities and to maintain transmission system reliability consistent with the NERC Mandatory Reliability Standards. The Customer is responsible for the reliability, availability and the protection of its own facilities. All facilities constructed to meet a Customer's load interconnection request will be designed, installed, operated and maintained in accordance with Good Utility Practice, the National Electrical Code, National Electrical Safety Code, equipment manufacturer's requirements, approved North American Electric Reliability Corporation and Regional Entity reliability standards, any applicable independent system operator or ATC planning criteria<sup>9</sup> and guidelines, and all other applicable laws, rules and regulations.

### 3.2.1 Customer Submittals Prior to Design Work

The Customer shall submit the following information after the LIRF has been accepted and the planning analysis performed, including any BVP, and prior to ATC initiating design work:

- A substation three-line diagram that includes substation phasing,
- A general arrangement diagram,
- Proposed modifications to Common Facilities,
- The power transformer nameplate drawing and the manufacturer's performance specification or test report, if it's available,
- A detailed description of the protection scheme to be used on the Customer's power transformer(s), and
- An executed PCA or as necessary, an executed Facilities Construction Agreement if ATC's Elective Load Interconnection Facilities Business Practice applies.<sup>10</sup>

---

<sup>9</sup> See ATC planning criteria at <http://www.atc10yearplan.com/PF7.shtml>

<sup>10</sup> Any transaction  $\geq$  \$ 25,000 with an ATC affiliate must be reported to the Public Service Commission of Wisconsin.

### 3.2.2 Customer Submittals During Design Work

The Customer shall also provide the information listed below to ATC for review and approval prior to completion of required design work. The information can be submitted electronically (.pdf format for example) or printed copies of drawings, whichever is convenient. *Please allow three weeks for ATC's review of the submitted information and at least three weeks for the Customer's consideration of ATC comments or modifications prior to the start of project construction:*

- As available, current transformer (“CT”) ratio correction curves and excitation curves for any CTs that may be used in ATC protection schemes ,and
- A Customer-owned line conductor terminal structure design.
- If the interconnection is to a substation bus protected by an ATC bus differential relay; the Customer must provide AC schematics showing proposed changes and additions to the current inputs to the ATC bus differential relay and DC schematics showing tripping and breaker failure functionality.
- If interconnection is to a substation bus tripped by an ATC bus lockout relay; the Customer must provide DC schematics showing Customer breaker failure relay trip outputs, test switches, and connection to the ATC protective devices.

### 3.2.3 Elective Facilities

The Customer may request interconnection facilities beyond those ATC would normally determine as appropriate for a given interconnection request. The cost responsibilities for the incremental facilities will be determined during the Best Value Planning process. ATC may agree to provide such facilities provided that the following conditions are satisfied:

- The Customer agrees to finance and pay the construction cost difference (including any applicable taxes) between the Customer-requested facilities and those ATC determines appropriate.
- The Customer-requested facilities meet all regulatory and reliability standards requirements and pose no additional risks or obligations on for ATC's operations or maintenance of ATC's facilities.
- ATC can obtain all necessary permits and approvals.

Please consult ATC Business Practice, Elective Load Interconnection Facilities for additional information. See the ATC website <http://www.atcllc.com>.

## 3.3 Procedures for Coordinated Joint Studies of New Facilities and Their Impacts on the Interconnected Transmission Systems

Please refer to Section 2.1 above for additional details.

## 3.4 Procedures for Notification of New or Modified Facilities to Others (Those Responsible for the Reliability of the Interconnected Transmission Systems) as soon as Feasible

Please refer to Section 2.2 above for additional details.

## 3.5 Design of Common Facilities

Depending on the substation's ownership, ATC or the Customer may own facilities that are used by multiple parties at that substation. However, ATC will not share a joint substation or any common facilities with an end-use customer for load interconnections made directly from transmission facilities to an end-use customer's facilities.

For further information regarding Common Facilities, please consult ATC's Joint-use Substations -- Common Facilities Business Practice<sup>11</sup> for more details on how ATC and the Customer should coordinate the design, addition or modification of common facilities. All Common Facilities will be designed to meet ATC Design Criteria, all applicable national and state electrical and safety codes, and all applicable NERC, Federal, State, MRO (or Reliability *Firm*) and MISO standards and policies for Transmission Owner interconnection service to a Local Distribution Company. Any differences or conflicts between the Customer's standards and ATC standards will be addressed in the design of the Common Facilities. The Customer shall provide a common facilities design proposal for ATC review and comment prior to any construction.

### 3.6 Interconnection Configuration

The configuration of interconnection facilities will take into account both the immediate and future plans for the new or modified substation. Where economically advantageous, future requirements of the Customer and ATC will be incorporated into the immediate substation design associated with the load interconnection request. ATC strongly advocates three phase interconnections with balanced load between all three phases. ATC may consider exceptions to this configuration on a case-by-case basis.

The interconnection facility configuration is considered by ATC a joint development effort. In addition to meeting the Customer's needs, ATC's design requirements are intended to facilitate ongoing maintenance and the required reliability of the transmission system, with minimal dependence on Customer load switching and/or load bridging<sup>12</sup>. ATC's facilities design will endeavor to include the most effective and least-cost design of both transmission and distribution facilities in order to minimize the frequency and duration of Customer interruptions. The jointly agreed to electric facilities design will be documented in the BVP Report. Examples of typical interconnection configurations can be found in Appendix F.

#### 3.6.1 Line Topology, Line Sectionalizing

ATC prefers to design its new facilities to sectionalize the affected transmission line's<sup>13</sup> load in a way that provides the greatest reliability for ATC's facilities as well as the Customer's. Sectionalizing the affected transmission lines may include load-break switches, remote-controlled line switches, auto-sectionalizers, motor-operated disconnects or breakers. The consideration of the appropriate sectionalizing method and equipment choice will be made on a case-by-case basis subject to the approval of ATC Operations, Maintenance and Engineering groups. The following criteria may be used in designing and sectionalizing transmission lines, unless ATC and the Customer determine that other criteria should apply:

3.6.1.1 Sectionalizing Criteria - 30 MW: When the new request affects a transmission line's load<sup>14</sup> to be greater than or equal to 30 MW, then ATC will split the load on the existing line by adding breakers per Section 3.21.3 at an appropriate location to maximize transmission line performance.

3.6.1.2 Sectionalizing Criteria - 300 MW-miles: Another factor to be considered is the product of line length (in miles) and the load (in MW) on the transmission line. If this product is equal to or greater than

<sup>11</sup> See ATC Business Practice "Joint Use Substations – Cost Responsibility For Common Facilities" [http://www.atllc.com/CR\\_bp.shtml](http://www.atllc.com/CR_bp.shtml)

<sup>12</sup> Please refer to the ATC Business Practice Load Bridging for Transmission Related Work.

<sup>13</sup> A transmission line is defined as a segment of the ATC Transmission System found between two circuit breakers.

<sup>14</sup> The term "load" as used here is the maximum forecast load as discussed in Section 2.1 of this Guide.

300 MW-miles, then ATC in collaboration with the Customer will consider determining the most appropriate manner to sectionalize the affected transmission lines.

3.6.1.3 Reliability Considerations: Some load interconnections may require consideration of other criteria in those instances when it is anticipated that the transmission lines may not perform adequately or reliably as a result of the load interconnection. (see Sections 3.6.1.4 and 3.6.1.5 below). ATC may consider other criteria in order to sectionalize the affected transmission lines in a reasonable and reliable manner.

3.6.1.4 ATC Reliability Performance Metrics: ATC monitors transmission system reliability performance as related to load interconnection (delivery) points using a performance metric. The ultimate goal is to understand the ongoing performance of an integrated transmission and distribution system, but at very specific interconnection points. This performance metric is significantly affected by not only the transmission system performance, but also the design and performance of the interconnected distribution system. For example, a local distribution company's ability to bridge distribution loads (especially automatically) will have substantial impact on ATC's delivery point metric which in part measures the number of end-use customers impacted by outages.

When considering the line sectionalizing requirements for any load interconnection, ATC may consider the performance of the existing transmission line affected by the new load interconnection request relative to ATC's other lines' delivery point metrics performance. ATC may determine not to sectionalize an affected transmission line if to do so would decrease its performance reliability based upon the performance metrics measured by ATC.

3.6.1.5 Distribution Change-Over: Transmission line sectionalizing may not be necessary if the distribution facilities incorporate bridging capability.

3.6.1.6 Number of Taps: Multiple taps between breakers may; 1) affect Customer service reliability, 2) complicate load bridging and operations, and 3) increase response time to isolate disturbances. Therefore, the number of existing taps on the transmission line affected by the new load interconnection request is a factor that ATC will consider when determining the effective line sectionalizing design. However, in general for lines with three or more taps (new plus existing), ATC will consider the design of line sectionalizing as set forth in Section 3.21.4. and Appendix F below.

3.6.1.7 Number of End-Use Customers: The number of end-use customers normally connected to the local distribution system could be a factor that should be taken into account when considering effective transmission line sectionalization. However, in general, for transmission lines that support more than 3,000 end-use customers ATC will design line sectionalizing as already provided for in Section 3.21.4.

3.6.1.8 Underground Transmission Lines: Substations served with underground transmission lines require additional consideration and will be handled on a case-by-case basis as a result of the risk of long-term outages resulting from underground cable failure. ATC Operations, Maintenance and Engineering groups may be required to participate in the facilities design with Planning.

3.6.1.9 Sectionalizing Device Ratings/Capability: Aside from the guidance derived from the line sectionalizing design criteria discussed above, load break capability and short circuit current interruption requirements of the transmission line under consideration may require installation of line sectionalizing devices that are designed to withstand high current applications.

While these criteria are specific, in some exceptional cases, the Best Value Planning study and analysis may need to be sensitive to case-specific considerations not otherwise addressed in these guidelines.

ATC and its Customers will coordinate the application and use of sectionalizing devices as part of the development of the interconnection project.

### 3.6.2 Line Topology –

#### 3.6.2.1 Radial versus Loop-through Connections

ATC and its Customer will jointly decide on the optimum means of connecting a new substation to the ATC Transmission System. To encourage efficient land usage for load interconnections, ATC will provide a straight bus (loop feed) substation for any new load interconnection substation with an ultimate configuration of two or more transformers.

When modifying an existing load interconnection substation with one transformer that is radially fed and the Customer load growth subsequently calls for two or more transformers, ATC and the Customer will utilize the BVP process on a case-by-case basis to determine if the substation should be converted to a loop-through substation instead of establishing a second radial feed into the substation. Land availability, substation proximity to the transmission line, the need for line breakers, load bridging capability of the distribution system and other related issues will be jointly considered.

3.6.3 Phase Rotation

ATC phase rotation is ABC (counter-clockwise). The Customer will exercise careful coordination with ATC to match this phase rotation to the Customer’s specific phase designations. For new interconnections, the LDC typically specifies the phase rotation for the interconnection facility. When ATC was formed, it was recognized that the phase rotation configurations vary from contributor –to-contributor. Table 4 below highlights the phase rotation conventions used by the various Balancing Authorities interconnecting to the ATC Transmission System.

Table 4				
Balancing Areas		Phase to Phase		
Wisconsin Public Service Corporation		C	A	B
Wisconsin Power and Light Company		A	B	C
Madison Gas and Electric		A	B	C
Wisconsin Electric Power Company		A	B	C
Upper Peninsula Power Company		A	B	C
Edison Sault Electric Light Company		A	B	C
Cloverland / Edison Sault (West)	(See Note 2)	A	B	C
Cloverland / Edison Sault (East)	(See Note 3)	C	B	A
General Notes:				
Note 1. All systems have A – B – C rotation				
Note 2. Cloverland / Edison Sault Substations; West of Hiawatha Substation				
Note 3. Cloverland / Edison Sault Substations; Hiawatha Substation and East				

3.7 Voltage Level and MW and MVAR Capacity or Demand at the Point of Interconnection

3.7.1 Voltage Level

The design of the new interconnections must effectively address the voltage requirements of both this Section and in Section 3.13 (voltage, reactive power & power factor). ATC operates transmission facilities predominantly at nominal system voltages of 69, 138, 345 kV and are further detailed in ATC Design Criteria. For the purposes of this guide, any reference to 138kV voltage levels shall also encompass interconnections to ATC’s 115 kV system as well. ATC will discuss with the Customer on a case-by-case basis requirements associated with interconnections to the relatively small amount of 161 and 230 kV facilities owned and operated by ATC.

The service voltage will depend on 1) the location of Customer Facilities relative to ATC’s existing facilities and 2) the present and future load the Customer intends to serve. The Customer shall consult with ATC on how these issues will affect service voltage selection.

3.7.1.1 Basic Impulse Insulation Level

The substation equipment and bus systems shall be designed for the voltage ratings shown below. Substations designed for 230kV and 161kV shall be dealt with as an exception. New substations energized

at 115kV shall be built to 138kV ratings in accordance with Table 5. Additions to existing substations energized at 115kV or 138kV, with 550kV BIL construction shall be continued similar to their original design and in all other cases consideration shall be given to the existing substation design.

<b>Table 5: Equipment Voltage Ratings<sup>2</sup></b>		
<b><u>Nominal Operating Voltage (phase-to-phase)</u></b>	<b><u>138 kV</u></b>	<b><u>69 kV</u></b>
Nominal Phase-to-Phase Voltage	138 kV	69 kV
Nominal Phase-to-Ground Voltage	80 kV	40 kV
Maximum Phase-to-Phase Voltage	145 kV	72.5 kV
Maximum Phase-to-Ground Voltage	84 kV	42 kV
Basic Insulation Level (BIL)	650 kV <sup>1</sup>	350 kV
1. In some remote locations and transformers a 550 kV BIL may be acceptable.		
2. Note: The ATC bandwidth for Operating Voltage is $\pm 5\%$ of the Nominal Operating Voltage		

### 3.7.2 MW and MVAR Capacity or Demand at the Point of Interconnection

ATC and the Customer will work together in the design of the Interconnection Facilities to provide sufficient MW and MVAR capacity at the Point of Interconnection for both current and future needs of both parties as determined by the collaborative Best Value Planning process.

## 3.8 Breaker Duty and Surge Protection

### 3.8.1 Fault Current

Customer Interconnection Facilities connected to ATC's Transmission System can be subjected to fault levels that are largely the product of system characteristics and interconnection impedance. The design of the Customer's Interconnection Facilities must possess sufficient fault interrupting and momentary withstand ratings to meet the maximum expected fault current, with appropriate margin for future system growth (See also Section 3.15.4 Circuit Breakers).

### 3.8.2 Continuous Current Ratings

ATC will endeavor to design facilities for the maximum continuous load that the Customer forecasts in the interconnection request or the next highest ATC standard rating for equipment beyond the maximum continuous rating of the Customer's transformer. The minimum continuous rating for new ATC substation facilities will be 2,000 amps. The minimum continuous rating for new ATC transmission line tap switches will be 1,200 amps. Any consideration of planned or emergency overloads are to be provided for in the LIRF.

### 3.8.3 Transient and Fault Duty Ratings

Customer Facilities are to be designed to include sufficient fault interrupting and momentary withstand ratings to meet the maximum expected transmission system requirements, with appropriate margin for future system growth. Equipment fault ratings will be determined for each interconnection as part of the project development process.

### 3.8.4 Shielding, Grounding & Surge Protection

ATC's requirements for shielding, grounding, and surge protection are addressed in ATC Design Criteria. Surge protection for Customer-owned equipment shall be designed and incorporated to be independent of ATC's surge protection for ATC's equipment.

All Interconnection Facility equipment must be adequately designed to meet surge protection and shielding requirements. ATC and the Customer will coordinate with each other in a manner that will provide the necessary data at the request of either party.

## 3.9 System Protection and Coordination

The Customer's protective system design must include provisions for separating from ATC's system. The Customer shall provide the protective system design for ATC's review and approval consistent with the interconnection agreement between ATC and its Customer.

### 3.9.1 Protection and Control Guidelines

To minimize disturbances to the ATC system, the Customer must design its interconnection facilities to protect its transformer with a Customer-owned protection scheme utilizing a circuit breaker, circuit switcher, or fuse<sup>15</sup> as appropriate for the primary tripping device. The Customer shall coordinate all aspects of their protection scheme with the ATC System Protection Department.

Examples of situations that may require additional review by the ATC System Protection Department include (but are not limited to):

- Any generation normally connected to the local distribution system where the distribution – connected generation is  $\geq 1/3$  of the minimum load at the substation or transformer,
- Normally-closed distribution voltage bus tie breaker(s) between at least two separate transmission sources,
- Situations that include the use of transfer trip or direct transfer trip protection schemes, and
- Load interconnections to end-use customers.

### 3.9.2 Control Circuit Practices

The specifics of the protection requirements design will be dictated by a number of factors, such as available communication facilities, line length and construction, interconnection on a black start path, mutual effects, available fault currents, critical clearing times, circuit breaker characteristics, etc. However, in general the requirements in the following sections will apply.

### 3.9.3 General Requirements

ATC's protective relay systems for transmission facilities are generally designed to provide some level of redundancy. ATC installs two relay protection schemes, primary and backup, for line and bus protection. The primary and backup schemes will use separate AC current and voltage sources, separate DC control circuits, and separate circuit breaker trip coils. Redundant batteries are generally not required.

Accordingly, ATC's bus protection scheme design utilizes two (2) bus differentials, connected to two (2) separate sets of current transformers as a best practice. Determination of the required number of CTs, the location of the CTs, the CT ratio and accuracy class for both new interconnections and replacements of existing distribution transformers must be made in conjunction with ATC System Protection on a project specific basis, taking into account both the existing configuration and future plans for the substation.

ATC requires engineering review of any modifications to its Customer's protective relay or control circuits consistent with the D-T IA. This review should take place during the engineering phase of the project.

When designing and installing protective relay systems, the Customer is encouraged to install equipment with replaceable indicating lamps or other obvious indicators that show at a glance the operating status of the Customer's transformer protective device and ATC's equipment.

### 3.9.4 Instrument Transformers

ATC includes instrument transformers as part of its protective relay design. Generally ATC does not provide instrument transformers for BA metering purposes, but will provide output where applicable. Refer to the

---

<sup>15</sup> Fuses are only permitted as protection on Customer-owned 69 kV transformers with base ratings  $\leq 15$  MVA.

“Coordination of Balancing Authority Metering Boundary Modifications” Business Practice for additional information.

### 3.9.5 Distribution-Connected Generation

In those situations where there are distribution-connected generating facilities associated with the Customer’s distribution system, care must be taken to protect the ATC Transmission System from fault currents. . ATC recommends that any generation without sufficient synchronizing capabilities be disconnected before reconnecting the Customer to ATC’s transmission system. The Customer must own the protection devices and protect ATC’s bus from any back feed from the distribution-connected generation. This is further discussed in Article 6.2 of the D-T IA:

“To the extent that there is generation on the Distribution System which, in the reasonable judgment of either Party, may contribute material amounts of current to a fault on the Transmission System, the Local Distribution Company shall have and enforce standards to ensure the provision, installation and maintenance of relays, circuit breakers, and all other devices necessary to promptly remove any fault contribution of such generation to any short circuit occurring on the Transmission System and not otherwise isolated by the Transmission Owner equipment. Such protective equipment shall include, without limitation, a disconnecting device or switch with load interrupting capability to be located between the generation and the Transmission System at an accessible, secure, and satisfactory site selected upon mutual agreement of the Parties. Transmission Owner shall not be responsible for protection of such generation.”

#### 3.9.5.1 Distribution-Connected Generation Reliability and Safety Related Issues

Since Delta-wye transformer configurations are the preferred means of interconnecting load to the ATC Transmission System, when the nature of a load interconnection changes due to the addition of distribution-connected generation (for both changes to existing as well as new load interconnections ) it is important for ATC to assess the potential for adverse impacts to the ATC Transmission System. This is especially true when the name plate rating of the distribution-connected generation is greater than or equal to ( $\geq$ ) 1/3 of the minimum load at the substation or transformer. The reliability and safety related design issues that need to be reviewed includes (but are not limited to):

- Transmission System network impact,
- System protection requirements to mitigate back-feed into a fault on the ATC transmission system, and
- Insulation coordination of substation and line equipment (including arrestors and potential transformers). (See Sections 3.7.1.1 and 3.12 also)

As described in Table 1 on page 4, it is requested that ATC be advised of all new distribution connected generators at a load interconnection point with a combined nameplate rating greater than 1 MW. That information may be submitted to ATC via a LIRF. The generator addition will then be assessed within ATC to determine the system impact and if additional analysis and/or system upgrades are needed.

If ATC and its Customer agree that Voltage Transformers (VTs) are required to support the Customer’s protection systems to separate the distribution system from the ATC Transmission System, the VTs should be installed on the Customer side of the interconnection and owned by the Customer. If Best Value Planning and/or substation space limitations result in the Voltage Transformers being install on the ATC side of the Customer’s disconnecting device, then it is appropriate for ATC to own and maintain the VTs consistent with the Distribution – Transmission Interconnection Agreement. Determination of the appropriate voltage class for ATC-owned VTs will be determined as part of the design of the Interconnection Facilities.

### 3.9.5.2 Distribution-Connected Generation Synchronizing Requirements

The Customer is responsible to ensure that the design of the Customer's Distribution System provides for the synchronization of the Distribution-Connected Generating Facility to the Customer's Distribution System.

### 3.9.6 Re-closing

ATC's transmission line re-closing practice after a breaker has opened during an operation is to re-close the transmission line one or more seconds after a line breaker has tripped open. The Customer is responsible for designing its Distribution System to have all sources of back-feed off of the distribution line prior to any ATC re-close attempts. This includes any Customer-owned throw-over schemes. ATC will address timing considerations with its Customer on a project-specific basis.

### 3.9.7 Breaker Failure

#### Network connections

In the event of a bus fault or breaker failure condition on the transmission system, ATC will send a trip signal to the Customer to trip their high-side interrupting device.

ATC's practice is to receive two (2) separate trip outputs from the Customer's high-side interrupting device breaker failure relay. One of these outputs will be wired to trip the interconnecting bus lockout and the other will trip the interconnecting bus relay which will direct trip the breakers on the interconnecting bus. If the Customer is unable to provide two (2) separate breaker failure trip output contacts, the single contact will be used to trip the interconnecting bus lockout.

Test switches should be installed in the same control house as the Customer's breaker failure relay. The required test switches will be placed such that they allow for operation of lockout relays, while preventing breaker failure operations and / or tripping of the Interconnection Facilities.

#### Radial connections

If the Customer-owned equipment could be a source into a line fault (such as networked distribution), the Customer's protective scheme design shall be capable of recognizing a fault condition and isolating the fault from the transmission line. For a radial connection, Customer-owned high side protective device failure presents a risk to both the Customer and ATC. Customer-owned equipment is at risk of catastrophic failure due to a sustained fault. The Customer is responsible for mitigating these risks in the design of its protective systems.

#### 3.9.7.1 Test Switches

Each Party's protective relay design shall incorporate the necessary test switches to perform the tests required for the pre- and post – in-service testing discussed in Section 3.19. The required test switches will be placed such that they allow operation of lockout relays while preventing breaker failure operations and/or tripping of the Interconnection Facilities

### 3.9.8 Substation Electrical Service

The Customer will consult with appropriate ATC personnel for the design of substation AC and DC systems that will be connected to ATC equipment.

Additional information on control circuit practices can be discussed with ATC as part of the development of the interconnection project. (See also ATC Business Practice “Transmission Related Station Power Use at Substations” which can be found on the ATC website [http://www.atcllc.com.CR\\_bp.shtml](http://www.atcllc.com.CR_bp.shtml).)

## 3.10 Metering and Telecommunications

### 3.10.1 Communications

ATC will install the communications facilities determined by ATC to be necessary at loop connected load interconnection substations. The communication facilities may be utilized for protection, control or metering applications as appropriate. ATC will design communication facilities for their use to match existing methods employed on the existing line. The communication methods may include, but are not limited to, telephone circuits, fiber optic networks, or other technologies as appropriate. ATC will identify for the Customer the space requirements necessary to accommodate ATC's communication requirements in the Interconnection Facilities.

### 3.10.2 SCADA / RTU

ATC encourages Customers to control distribution lines that are interconnected to ATC substations remotely via SCADA for potential emergencies including, but not limited to, system restoration activities following a blackout or reduction and/or control of loadings for other unanticipated events.

### 3.10.3 Revenue Metering

Since the Customer and ATC will all monitor metering data, they shall together determine the design requirements for interconnection revenue metering on a project-specific basis. Primary instrument transformers/devices will be revenue class, preferably wound-type current transformers, and voltage transformers that are accessible to the Customer and ATC.

### 3.10.4 Balancing Area Metering

Consult ATC's Coordination of Balancing Authority Business Practice for guidance on the design and installation of appropriate Balancing Authority Area (BAA) facilities for any load interconnection project that impacts a BAA boundary. In general ATC does not install instrument transformers associated with any required BAA metering. For BAA metering at any existing load interconnection substations, the Customer will install, own, and maintain any cables necessary to connect to any ATC transmission-connected instrument transformers.

## 3.11 Grounding and Safety Issues

As set forth in the D-TIA, the Customer and ATC must agree to operate their respective facilities taking into account the ratings and capabilities of the facilities of the other party and shall not operate their system in a manner that would result in exceeding the operating limits or equipment ratings of the other party. This includes the coordination and use of appropriately sized grounding equipment as part of the Interconnection Facilities' design.

### 3.11.1 Effective Grounding

ATC maintains effective grounding on its transmission system facilities, as defined by NESC. All Customer Facilities connected to the ATC Transmission System must be designed to be effectively grounded per the NESC requirement. These calculations should be made as if the ATC Transmission System was disconnected

from the Customer. The Customer must meet the effective grounded system criterion independent of the ATC Transmission System.

### 3.11.2 Grounding System

The Customer is responsible for the appropriate grounding of their equipment. At the Point of Interconnection, the Customer’s grounding equipment must be compatible with ATC’s grounding equipment. The Customer shall submit the grounding system study and design for ATC review prior to construction. The ground grid design must comply with IEEE 80 and properly address site extremes. Site tests should be completed to determine soil resistivity prior to ground grid design. Post construction grid resistance testing should be performed to verify design assumptions and that the installation was completed per the ground grid design. ATC grounding standards are available upon request.

### 3.11.3 Safety Issues

All personnel switching, working on or in proximity to the Interconnection Facility will comply with all safety policies, manuals and procedures of the applicable Interconnection Party along with all applicable OSHA safety laws and federal, state, and local rules and regulations.

The Customer and ATC will agree to work together to develop appropriate switching procedures to be utilized at the Interconnection Facilities.

All Customer equipment must be designed physically and electrically to allow for the attachment of properly sized working grounds as specified in IEEE 1246 “Guide for Temporary Protective Grounding Systems Used in Substations.”

## 3.12 Insulation and Insulation Coordination (Basic Impulse Insulation Level)

ATC and the Customer must ensure that all equipment is adequately protected from excessive system over-voltages. This includes selection of equipment Basic Impulse Insulation Level (BIL) and protective devices (e.g. surge arresters) to achieve proper insulation coordination across the distribution – transmission interconnection.

ATC designs its transmission facilities for the BILs shown in Table 6. Interconnections at 230kV or 161kV will be reviewed on an exception basis. New substations energized at 115kV will be built to 138kV ratings in accordance with 138 kV standards. Additions to existing substations energized at 115kV or 138kV, with 550kV BIL construction will be continued similar to their original design. In all other cases consideration will be given to the existing substation design.

Nominal Operating Voltage (phase-to-phase)	138 kV	69 kV
Basic Insulation Level (BIL)	650 kV <sup>1</sup>	350 kV
1. In some remote locations and transformers a 550 kV BIL may be acceptable.		

## 3.13 Voltage, Reactive Power, and Power Factor Control

### 3.13.1 Steady State Voltage Range

The Customer should expect a normal transmission operating voltage range of +/- 5% from nominal. During system contingency or emergency operation, ATC permits operating voltages to vary up to +/- 10% from

nominal. The Customer's equipment should be designed appropriately to operate and maintain adequate voltage under these conditions.

### 3.13.2 Transmission Line Reactive Capability

All interconnections will be designed to be reactive compensated pursuant to Good Utility Practice to ensure proper operation of the interconnection. The Customer must provide their own reactive support for their Interconnection Facilities.

### 3.13.3 Load Interconnection Power Factor Guidelines

ATC's Customers should plan, design and maintain their load interconnection facilities in order to maintain a power factor at the low side of the load interconnection transformer that is greater than 95% lagging when the load is greater than 85% of maximum forecast load at that load interconnection.

Customer reactive resources should be designed with the ability to be switched off during light loading periods. This applies to any load interconnection where transmission system Best Value Planning indicates a need for transmission system power factor improvement at that load interconnection.

For cost allocation purposes, if the Customer load interconnection power factor derived from the Customer's most recent load forecast is below 95% lagging, the Customer will be responsible to bring the power factor up to the 95% level and ATC will be responsible to bring the power factor up to the level identified in the Best Value Plan. Costs will be allocated between ATC and the Customer based upon a ratio of the Customer capacitor banks installed. If the load interconnection power factor is already above the 95% lagging level and additional transmission system power factor improvement is identified in the Best Value Plan to address the transmission system need, then ATC will reimburse the Customer(s) for the additional Customer capacitor banks identified in the Best Value Plan consistent with its Capacitor Bank Business Practice<sup>16</sup>. The Customer is responsible for maintaining the 95% (or greater) lagging power factor at the load interconnection regardless of previous capacitor bank contributions requested by ATC.

## 3.14 Power Quality Impacts

### 3.14.1 Voltage Flicker and Harmonics

The energization and operation of any facilities on the Customer's side of the interconnection facilities must be consistent with ATC's Planning Criteria<sup>17</sup> and Operating Instructions (available upon request) regarding permissible voltage deviations, harmonics, flicker and distortion.

### 3.14.2 Frequency and Frequency Control

The Customer should expect a normal transmission operating voltage range of +/- 5% from nominal. During system contingency or emergency operation, ATC permits operating voltages to vary up to +/- 10% from nominal. The Customer's equipment should be designed appropriately to operate and maintain adequate frequency under these conditions. For Distribution-Connected Generation, energy delivered into the ATC Transmission System must be 60 Hz sinusoidal alternating current as a standard frequency. In accordance with

---

<sup>16</sup> See ATC Business Practice 0302 entitled "Capacitor Bank Installations on Distribution Systems for Transmission Benefit" which can be found at: [http://www.atcllc.com/CR\\_bp.shtml](http://www.atcllc.com/CR_bp.shtml).

<sup>17</sup> See ATC planning criteria at <http://www.atc10yearplan.com/PF7.shtml>

Applicable Reliability Standards, the Customer will design and install both control and protective relaying equipment necessary to maintain proper transmission system frequency.

### 3.15 Substation Equipment Ratings

The Customer and ATC must agree on the applicable substation/transmission/protection design guides, standards, and specifications to be used, for the design of and procurement for the interconnection of the Customer's facility(ies). Both Parties will be afforded the opportunity to confirm the overall Interconnection Facility capabilities and identify the limiting transmission element within the Interconnection Facility.

As set forth in the D-TIA, the Customer and ATC will be obligated to operate their respective facilities taking into account the ratings and capabilities of the facilities of the other party and shall not operate their respective systems in a manner that would result in exceeding the operating limits or equipment ratings of the other party. This includes the coordination of the topics discussed in Sections 3.15.1 through 3.15.6 below.

#### 3.15.1 Voltage and BIL Levels

See Section 3.12 above.

#### 3.15.2 Current Ratings

ATC and the Customer shall coordinate Interconnection Facility equipment current ratings with each other during the design of the Interconnection Facilities.

#### 3.15.3 Bus Spacing and Clearances

ATC substation and bus systems shall be designed to match existing layouts when applicable, but at a minimum, new equipment shall maintain clearances and spacing consistent with the current ATC design standards, available upon request. ATC and the Customer shall coordinate substation and bus clearances and spacing with each other during the design of the Interconnection Facilities.

#### 3.15.4 Circuit Breakers

The ATC power circuit breakers at the substations are expected to be SF6 gas insulated, dead-tank type that conform to ANSI-C37. ATC will provide expected short circuit currents to the Customer to assist them in selecting the appropriate circuit breaker ratings during the design of the Interconnection Facilities.

#### 3.15.5 Disconnect Switches

ATC disconnect switches are expected to be three-phase, gang operated, horizontal-mounted, with station post insulators that conform to ANSI-C35.32. ATC and the Customer shall coordinate the application of disconnect switches with each other during the design of the Interconnection Facilities.

#### 3.15.6 Voltage Transformers (VTs & CCVTs)

Wound voltage transformers (VTs) are preferred for all 138 kV and lower bus voltage sensing and non-power line carrier applications on ATC Transmission System facilities. Voltage transformers will conform to ANSI-C35.13. Capacitance Coupled Voltage Transformers will conform with ANSI C93.1. ATC and the Customer shall coordinate the application of these VTs & CCVTs with each other during the design of the Interconnection Facilities.

## 3.16 Synchronizing of Facilities

### 3.16.1 Synchronism

ATC requires a synchronism check capabilities to be installed for all circuit breakers interconnecting the Customer's Interconnection Facilities to the ATC Transmission System (including situations where distribution connected generation or networked distribution systems are present. The synchronism check function along with additional voltage monitoring functions will supervise the closing of the interconnecting circuit breaker.

Manual closing of interconnecting circuit breakers requires verification of synchronism using sync-scope to prevent out of synchronization closing. If this is also the point of generator synchronization, it is highly recommended to install additional automatic synchronizing equipment.

ATC and the Customer shall coordinate the application of these devices during the design of the Interconnection Facilities.

### 3.16.2 Phase Rotation

The ATC Transmission System phase rotation is ABC counter-clockwise. The Customer should verify phase rotation with ATC before purchasing any equipment and proceeding with the Interconnection Facility construction. See Section 3.7.2 of this guide for additional information.

## 3.17 Maintenance Coordination

### 3.17.1 Maintenance Notification

The Customer must notify ATC or Midwest ISO as provided for in the applicable Midwest ISO ASM Tariff and the D-T IA of any unusual conditions including, but not limited to the following:

1. Partial operating capability due to equipment limitations.
2. Scheduled outage periods and return to service expectations. Return to service notification must be updated daily to reflect the recent progress or the lack of progress.

### 3.17.2 Maintenance

Interconnection equipment owned by the Customer should be maintained and inspected according to manufacturer recommendations, NERC, and/or industry standards. Procedures must be established for visual and operational inspections. Provisions should be established for equipment maintenance and testing as part of the Interconnection Facilities design.

ATC maintains the right to review the maintenance, calibration, and operation data of all protective equipment for protecting ATC facilities, ATC Customers, and other Interconnected Parties. The Customer is responsible for providing the necessary test accessories (such as relay test plugs, instruction manuals, wiring diagrams, etc.) required to test these protective devices. Verification testing may include the tripping of the interconnection breaker, as appropriate.

If ATC performs work on the premises of the Customer, ATC operating personnel may make an inspection of the work area. If ATC personnel deem working conditions to be hazardous, the Customer must correct the unsafe conditions before ATC personnel will perform their work.

### 3.18 Operational Issues (Abnormal Frequency and Voltages)

ATC and its Customers agree to coordinate the operation of their electrical systems at the points of interconnection in compliance with Good Utility Practice to prevent or minimize detrimental impacts on either Party's system as described In the D-T IA. As part of the Interconnection Facilities design, ATC and the Customer will work together to establish appropriate procedures, protocols and operating guides (if necessary) to account for and manage abnormal frequency, voltages or other operating limits on either party's transmission system in accordance with all appropriate industry standards, Mandatory Reliability Standards, and Good Utility Practice.

### 3.19 Inspection Requirements for Existing or New Facilities

#### 3.19.1 Acceptance Testing, Inspection and Commissioning

ATC requires all Customers proposing to interconnect to the ATC Transmission System be in compliance with the applicable testing and/or performance requirements as part of the Interconnection Facilities design.

#### 3.19.2 General

Prior to energizing the interconnection equipment with the ATC Transmission System, the Customer and ATC will work together to insure that all pertinent contracts (such as the D-T IA) are signed and that all equipment modifications have been completed. The Customer is required to demonstrate the correct operation of all interface protective and control devices to ATC. ATC shall define and witness, but is not responsible for performing this demonstration.

The Customer must provide detailed information on the protective relaying, metering, and control (including sync-check) equipment that will interface with the ATC Transmission System.

Scheduling of demonstration testing should be coordinated through ATC with a minimum of fifteen business days notice. Any outage of ATC protection equipment must be requested and approved in accordance with ATC's System Operation Approval Procedure for System Protection Equipment and Communication Channel Outages. This procedure is available upon request.

ATC commissioning specifications and documentation requirements are available upon request and provide the specific criteria that ATC uses for ensuring its electrical equipment is properly tested and checked out. Inspection and approval by ATC does not constitute a warranty or relieve the Customer of responsibility for the operating condition or installation of the equipment, and may not be relied upon by the Customer for that purpose. Once interconnected, ATC will retain the right to inspect the Interconnection Facilities at ATC's discretion.

#### 3.19.3 Demonstration

The Customer and ATC shall adhere to the following steps in assuring that the Interconnection Facilities have been adequately tested both prior to and after energization and interconnection to the ATC Transmission System:

- Construction Testing Documentation Review,
- Demonstration Tests,
- Post In-Services Tests.

Details on the specific testing requirements are to be coordinated between ATC and the Customer as part of the Commissioning process.

#### 3.19.4 Future Changes In Requirements

From time to time new requirements for testing, reporting, equipment and/or performance are established by NERC or Regional Entity for interconnections. The Customer should take steps so it is notified of any changes by the applicable entity.

#### 3.19.5 Performance of Tests

The Customer must test all wire, cable, electrical equipment, and systems installed by the Customer or connected by the Customer to assure proper installation, adjustment, setting, connection, and functioning. Details on the performance of specific testing requirements are to be coordinated between ATC and the Customer as part of the Commissioning process as well as on-going periodic testing processes.

#### 3.19.6 Test Equipment

The Customer must provide all equipment necessary to perform the tests required by ATC. Details on the specific testing equipment requirements are to be coordinated between ATC and the Customer prior to performing tests.

#### 3.19.7 ATC Supplied Equipment

Any ATC supplied equipment that is factory calibrated (transducers, pressure switches, tuners, etc.) shall be tested to verify calibration consistent with ATC testing practices. The use of ATC supplied equipment shall be coordinated with the appropriate ATC personnel prior to performing tests.

#### 3.19.8 Final Design / Final "Draft" As-Built Documents

The Customer must at the time of demonstration testing have a complete set of construction drawings and documentation available. ATC and the Customer will coordinate together what information is required prior to demonstration testing. ATC shall be provided a duplicate copy of this documentation at least fifteen business days prior to demonstration testing. A coordination meeting with ATC should be held to clarify any questions on documentation or testing requirements at least one week before demonstration testing begins.

### 3.20 Communications and Procedures During Normal and Emergency Operating Conditions

ATC and the Customer will design the Interconnection Facilities to function properly under both Normal and Emergency Operating Conditions. General guidelines will be stated below, but any specific guidelines will be defined in the D-T IA between ATC and the Customer. Communication protocols between ATC and the Customer will be consistent with industry standards and practices.

The Customer shall operate within the applicable guidelines of this document and any other specific requirements as stated in the D-TIA, if applicable.

### 3.20.1 Normal Conditions

The Customer must operate their interconnection facilities according to the instructions and approval given by the ATC system control center personnel. Additionally, it is expected that the Customer has twenty-four hour support available.

### 3.20.2 Abnormal Conditions

ATC reserves the right to open the interconnection disconnecting device for any of the following reasons:

1. ATC line maintenance work on ATC Transmission System.
2. ATC Transmission System emergency.
3. Inspection of a Customer's substation equipment and protective equipment reveals a hazardous condition.
4. Failure of the Customer to provide maintenance and testing reports when required.
5. Customer's Interconnection Facilities interfere with other ATC customers, other Interconnection Parties, or with the operation of the ATC Transmission System.
6. Customer has modified the Interconnection Facilities that affects ATC equipment without the knowledge and approval of ATC or has not installed ATC required protective devices.
7. Personnel or public safety are threatened.
8. Customer fails to comply with applicable OSHA Safety Tagging and Lockout requirements or ATC Hold Card Procedures.

Changes to the ATC Transmission System or the addition of other ATC Customer Interconnection Party's facilities, loads, or generators in the vicinity of the Customer's Interconnection Facilities may require modifications to the Customer's and ATC's interconnection protective devices. If such changes are required, the Customer may be subject to future charges for these modifications as described in the Distribution – Transmission Interconnection Agreement.

## 3.21 Transformers

### 3.21.1 Transformer Connections

The Customer shall clearly designate the proposed transformer connection scheme and provide drawings and test reports submitted to ATC. ATC prefers delta-grounded wye for the Customer's transformer connection scheme. ATC shall review other transformer configurations on a project specific basis depending on the circumstances.

### 3.21.2 Transformer Protection

The Customer shall install, own and maintain transformer protective equipment<sup>18</sup>, including surge protection devices on the Customer side of the Point of Interconnection. For straight bus applications, the Customer may design transformer protection using one of four options. The Customer will determine the most appropriate

---

<sup>18</sup> Note: All of the interconnection configuration drawings in Appendix F use a circuit switcher symbol to represent the general requirement of a customer-owned protective device per this section. A breaker or a fuse may be a viable and/or preferable alternative. Consult ATC for approval. The demarcation point (change of ownership point) is at the source-side terminal of the customer-owned disconnecting device.

option by considering the transmission connection, available fault current<sup>19</sup> and the Customer's standard practices. These options are:

- Option 1. - A circuit switcher or transrupter with an integral visible air-break switch, (see Section 3.21.4 for additional information on disconnect switches)
- Option 2. - A circuit switcher or transrupter **without** an integral visible air-break switch and an air-break switch in series with the circuit switcher or transrupter,
- Option 3. - A circuit breaker in series with a source-side disconnect switch installed at the load interconnection substation, or
- Option 4. - Fuses in series with an air-break switch (with the capability to break Customer transformer magnetizing current).

When the interconnection is made to a ring bus or breaker-and-a-half substation configuration, the Customer does not necessarily need to install a transformer high-side interrupting device – only a disconnect switch capable of breaking transformer magnetizing current. Customer-owned transformer relaying will trip ATC-owned circuit breakers in these configurations.

Additional design considerations include:

- The Customer's interrupting device shall not be designed to depend upon AC power, including capacitive trip devices, for tripping.
- ATC will provide expected short circuit currents for a specific location upon request.
- For options 1-4, the Customer's interconnection will contain current transformers sufficient for supporting an ATC bus differential protection scheme if necessary. All interconnections to breakered substations must meet this requirement. ATC has specific CT requirements for differential protection. See Section 3.9.3 for specific CT requirements.

ATC and its Customers will coordinate the application and use of transformer protection as part of the development and design of the interconnection project. As discussed in Sections 3.2.1 & 3.2.2 the Customer must submit the transformer manufacturer's test report prior to ATC initiating the design work and the CT ratio curves to ATC no later than three (3) weeks in advance of interconnection facility energization.

---

<sup>19</sup> Note: The high voltage device must be capable of interrupting the worst case fault current (from ATC) and not rely on bus tie breakers or line circuit breakers as low cost method for protecting for high current faults.

### 3.21.3 Circuit Breakers

If circuit breakers are required in the Interconnection Facilities design (typically when 30 MW of load is forecasted within the 10 year planning horizon), ATC will install a breaker on each of the line terminals at a straight bus load interconnection substation. The application of a bus-tie breaker will be considered when 30 MW of substation load is achieved. ATC may also elect to install breakers in any position deemed appropriate for reliable design when the subject interconnection substation includes more than two transmission line elements and/or a generation interconnection(s). While not preferable, ATC will consider on a case-specific basis installing a single-breaker scheme for a modified load interconnection at an existing substation only if space constraints prohibit a two-breaker installation.

ATC and its Customers will coordinate the application and use of circuit breakers as part of the development of the interconnection project.

If a Customer-owned circuit breaker is installed, CT requirements for ATC bus differential protection should be evaluated as needed. See Section 3.9.3 for specific CT requirements.

### 3.21.4 Disconnect Switches

Load interconnection facilities shall include disconnect switches located in appropriate places which are summarized here.

All line disconnect switches shall be installed on steel structures. Installation on wood structures is not acceptable (unless installation is temporary; i.e. scheduled to be removed within two years).

Since the configuration drawings in Appendix F provide details for any single load interconnection, Figure 1 is provided to show the minimum installation of mainline switches for a typical line with multiple radial load interconnections.<sup>20</sup>

---

<sup>20</sup> ATC and its Customer will work together to determine if 1) a radial connection is the most appropriate design for any single interconnection and 2) if switches D3 or D6 are necessary with respect to the length of the radial connection.

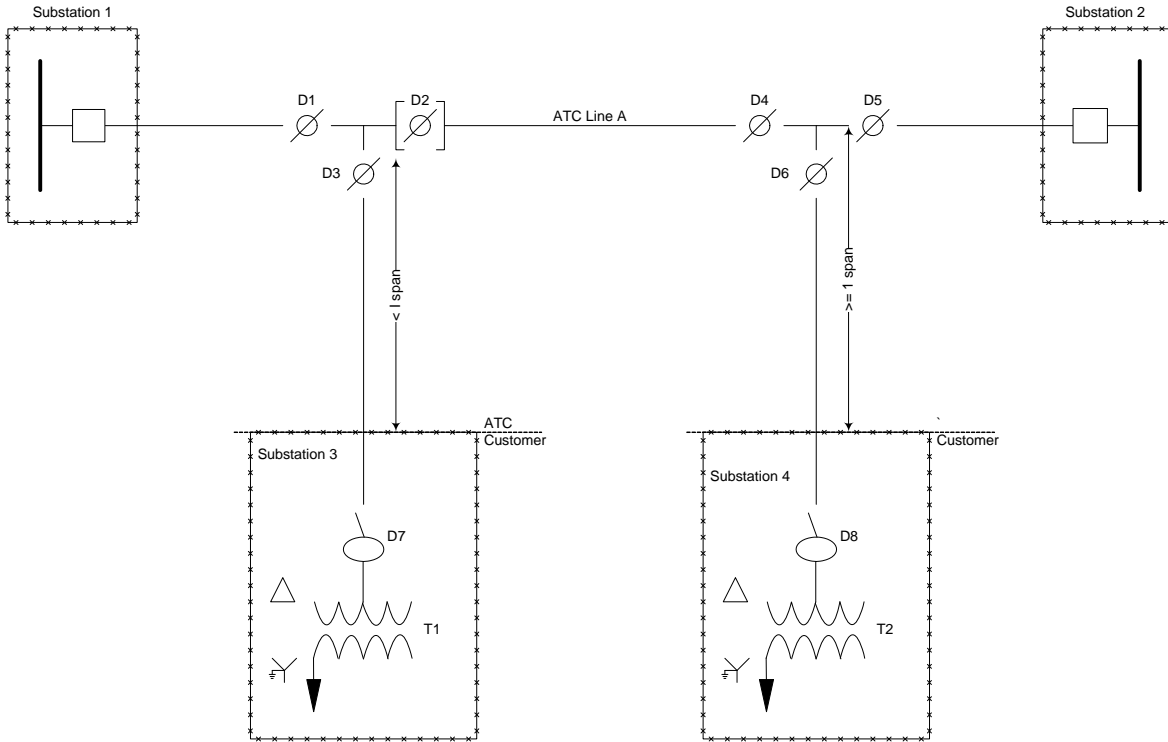

Figure 1: Typical switch installation on a line with multiple radials taps<sup>21</sup>

ATC will apply switches with load-break, loop-splitting and/or line-charging current break capability as necessary, after considering the proper current breaking capability of all proposed and existing disconnect switches on the transmission line(s) affected by the proposed interconnection.

Hydraulic motor-operators and RTUs are elective facilities for the convenience of the Customer and are paid for by the Customer. The exception to this statement is when the use of this equipment is determined to be appropriate per Section 3.6.1 of this Guide. ATC reserves the right to approve the design and equipment to be installed for these purposes since these devices directly impact the reliability of the switch installation.

For load interconnection requests that are on 69 kV lines, ATC will use phase-over-phase switch installations. In addition, ATC may install a 3-way switch to facilitate constructions and coordinate outages most effectively; unless the 69 kV line is only one span length in which case a 2-way switch may be installed.<sup>22</sup>

<sup>21</sup> A symbology key is available in Appendix F.

<sup>22</sup> Phase-over phase switch installation is only acceptable for 69 kV applications or where physical space in an existing right-of-way does not accommodate a horizontal mount installation. Hydraulic motor-operators are not permitted for phase-over-phase switch installations, since experience has demonstrated insufficient hydraulic pressure often results in switch contact not closing properly.

## 3.22 Physical Design Guidelines

### 3.22.1 Site Selection

One of the most critical factors in the design of a substation is its location. It is important that the site selected have sufficient space to accommodate the present and future Customer and/or ATC's use. The Customer should review all potential substation sites with ATC prior to purchasing property.

The preparation of the site should follow ATC Design Criteria. The Customer shall submit soil borings and resistivity reports to ATC for review and use in the design of ATC's transmission facilities.

The Customer should consider the following factors when siting a load interconnection substation:

- Environmental considerations, including previous site usage or possible permitting issues,
- Sufficient size to accommodate the ultimate interconnection configuration requirements,
- Ingress/egress, including proximity to all-weather roads and/or railroad siding for (heavy) equipment installation and removal,
- Proximity to existing transmission lines and other utilities,
- The availability of suitable right-of-way and access to the substation site for transmission lines,
- Proximity to potential contaminants (such as highway salt),
- Site maintenance requirements including repair, landscaping, and storage, and
- The ATC communication methods presently employed on the existing line to be tapped, including the availability or feasibility of other methods (microwave, fiber, power line carrier, leased phone-lines, and point-to-point radio).
- If a substation requires underground interconnection the cost for an underground load interconnection will be borne by the Customer, unless the interconnection is to be made to an existing ATC underground transmission line. The Customer should consult with ATC for design details regarding the feasibility of underground transmission facilities with respect to the location siting decision. Consult ATC Business Practice; Elective Undergrounding for additional details.

### 3.22.2 Space Requirements

When reasonably possible, the Customer will provide sufficient physical space to accommodate not only ATC and the Customer's present, but anticipated future use of the substation (see Appendix F for typical space requirements of each substation configuration). Such additional ATC requirements, beyond those outlined in the ATC Design Guide, may include transmission capacitor banks and/or additional ATC-owned elements (e.g. lines). Space required for an ATC capacitor bank is detailed in ATC Guide. The Customer should also consider its requirements for connection of a mobile substation as a means for load bridging under emergency outage circumstances.

The Customer shall also provide sufficient clearance from energized equipment to satisfy the NESC and ATC Design Criteria. To facilitate maintenance access, ATC prefers to maintain at least 30 feet of horizontal clearance between the substation fence and bus support structures or equipment. The Customer shall discuss exceptions with ATC as part of the design review process.

### 3.22.3 Ownership Demarcation

The Point of Interconnection will be where the Customer interconnection facilities connect to the ATC Transmission System.

### 3.22.3.1 Radial Connections

The point of interconnection between ATC and Customer-owned high voltage facilities will be at the Customer-end of the jumper connected to the ATC-owned line insulator connection at the Customer's dead-end structure. For an overhead ATC-owned transmission tap conductor terminated at a Customer-owned dead-end structure, the Customer will include provisions on that structure to accommodate the installation of surge arresters by either party, if necessary. Through the project team, ATC and its Customer will select an appropriate connector and coordinate responsibility for furnishing and installing the connectors as well as completing the final connection of the jumpers to the Customer-owned facilities.

### 3.22.3.2 Network Connections

The Customer's connection at the high voltage bus side terminal of the Customer-owned disconnecting device will be the physical point of transmission facilities ownership demarcation between ATC and Customer-owned facilities. Through the project team, ATC and its Customer will select an appropriate connector and coordinate responsibility for furnishing and installing the connectors as well as completing the final connection of the jumpers to the Customer-owned facilities.

The default Point Of Interconnection for interconnected bus differential relaying is located at the terminal of the Customer-owned CT's on the Customer-owned breaker or transformer. ATC owns all of the cables up to the Customer-owned CT's on the Customer-owned breaker or transformer.

## 3.22.4 Land Rights

### 3.22.4.1 Customer-Owned or Leased Substation Lands

The Customer shall furnish at no cost to ATC any necessary access, easements, licenses, and/or rights-of-way upon, over, under, and across lands owned by the Customer and/or its affiliated interests for the construction, operation and maintenance of necessary lines, substations, and other equipment to accomplish the requested interconnection. ATC will be responsible for obtaining land rights from third-parties. The Customer will be responsible for obtaining all of the appropriate permits for the substation.

### 3.22.4.2 ATC-Owned Substation Lands

ATC will furnish at no cost to the Customer any necessary access, easements, licenses, and/or rights of way upon, over, under, and across lands owned by ATC and/or its affiliated interests for the construction, operation and maintenance of the Customer's facilities. The Customer will be responsible for obtaining any land rights from third-parties. ATC will be responsible for obtaining all of the appropriate permits for the substation.

## 3.22.5 Clearances

Clearances to ATC substation facilities shall satisfy ATC Design Criteria

## 3.22.6 Line Termination Structures

The Customer and ATC shall carefully coordinate the substation design of the last span of wire between the last ATC transmission tower and the substation overhead line terminal structure(s). ATC and the Customer together will arrange the orientation of the substation in relation to ATC's incoming transmission line(s) to minimize line angles, turning towers, and crossings.

ATC will typically design the last full-tension tap span to terminate into an ATC-owned structure outside the Customer's radially fed load interconnection substation. However, where physical constraints dictate and ATC-owned transmission lines terminate at a Customer-owned terminal (dead-end) structure, the Customer will design the structure to support the loads identified for ATC's equipment provided by ATC's Design Engineering Department and those outlined in ATC Design Criteria.

### 3.22.7 Site Preparation

The following common facilities requirements are applicable to Customer-owned substations containing ATC equipment.

#### 3.22.7.1 Control Enclosures

The Customer will design control enclosures (buildings) that contain ATC relaying with sufficient space for convenient access to control panels - with at least 36 inches of clear space behind the panels and unobstructed access to substation batteries. Please review ATC Design Guide or refer to the latest version of the NESC for additional guidance

#### 3.22.7.2 Security / Access

The Customer will design, install, own, and maintain the substation fence.

The Customer will make provisions at both the substation gate and the control enclosure for an ATC lock, thereby enabling ATC access by an ATC-owned key.

The Customer will design the substation outdoor lighting system to provide adequate illumination for security, emergency ingress/egress, and position indication of disconnect switchblades. ATC does not require lighting for nighttime maintenance operations.

#### 3.22.7.3 Conduit / Raceway

The Customer will install, own, and maintain substation cable conduit and/or raceway systems.

#### 3.22.7.4 Signs and identification

The following requirements apply to all substations containing ATC equipment.

- For maximum effectiveness, the Customer will place security and identification signs at eye level (less than six feet and more than four feet above grade or floor level).
- On Customer-owned dead-end and/or switch structures, the Customer will provide phase identification signs on A, B, and C phases to indicate ATC standard phase rotation next to the termination device for each interconnection point.

### 3.23 References

The following documents provide additional guidance for use in the development of load interconnection facilities between ATC and its Customers:

- ATC Business Practice, Capacitor Bank Installations on Distribution Systems for Transmission Benefit (See the ATC website <http://www.atcllc.com>).

- ATC Business Practice, Coordination of Balancing Authority Metering Boundary Modifications (See the ATC website <http://www.atcllc.com>).
- ATC Business Practice, Elective Load Interconnection Facilities for additional information (See the ATC website <http://www.atcllc.com>).
- ATC Business Practice; Elective Undergrounding (See the ATC website <http://www.atcllc.com>).
- ATC Business Practice, Joint-use Substations -- Common Facilities (See the ATC website <http://www.atcllc.com>).
- ATC Business Practice; Load Bridging for Transmission Related Work (See the ATC website <http://www.atcllc.com>).
- ATC Design Criteria DS0000, Substation Design Criteria (Available upon request).
- ATC Design Engineering Guide GD-0280 (Available upon request).
- ATC Guide ECS-CD-8000; Substation Capacitor Bank (Available upon request).
- ATC Design Guide ECS-GD-2300; House, Substation Control (Available upon request).
- ATC Best Value Planning White Paper (See the ATC website: <http://www.atcllc.com/O.shtml>)
- Midwest ISO Tariff - Open Access Transmission, Energy and Operating Reserve Markets Tariff (ASM Tariff) - Midwest ISO FERC Electric Tariff, First Revised Vol. No. 1.
- National Electrical Code,
- National Electrical Safety Code.
- NERC Reliability Standard FAC-002-0 (See <http://www.nerc.com/files/FAC-002-0.pdf>)
- NERC Reliability Standard BAL-005-0.1b (See [http://www.nerc.com/files/BAL-005-0\\_1b.pdf](http://www.nerc.com/files/BAL-005-0_1b.pdf))

Effective Date: 12/30/11		<b>Revision: 2.0</b>
<b>TITLE:</b>	Load Interconnection Guide	<b>Page 36 of 76</b>
	Approved by: <i>Tom Fines</i>	

## Revision History

### Revision Information

Revision	Author	Date	Section	Description
2.0	John Raisler	12-30-11	All	Rearranged & added sections to align with FAC-001 requirements ordering of topics. Added Expanded Distribution Connected Generation discussion in 3.10.5 Added BVP Process Flow Diagram Appendix B Updated BVP Responsibilities Matrix Appendix C Updated LIRF example Added Revision History
1.0	John Raisler	10-09-09	All	New - Includes review by: System Protection, Operations, Commissioning, Safety, Substation Services, Environmental, Maintenance, Metering, Planning, Legal and Interconnection Services.

## Appendix A.1 – Glossary of Terms

Any capitalized terms not defined herein will have the meanings set forth in the MISO FERC Electric Tariff.

**ATC Design Criteria, ATC Guide:** are terms used to reference a series of design criteria documents and guides used internally at ATC to document specifications for various transmission facilities. (See Section 3.4 references) The documents are available upon request.

**ATC Transmission System:** the facilities owned by ATC subject to the administration of the MISO that are used to provide energy market, transmission, energy, and ancillary reserves market, interconnection services or Wholesale Distribution Service under the MISO FERC Electric Tariff.

**Balancing Authority:** an entity responsible for managing an electric system area (a Balancing Authority Area) bounded by interconnection metering and telemetry; and capable of controlling generation to maintain its interchange schedule with other Balancing Authority Areas and contributing to frequency regulation and which has received certification by NERC or a Regional Reliability Council of NERC.

**Best Value Planning (BVP):** means the consideration of, or evaluation of, one or more alternatives to the proposed construction of new, or the modification of existing, transmission facilities which have been identified in a planning process to determine whether an alternative or alternatives exists that may include the construction of new, or the modification of the existing, distribution facilities or transmission facilities owned by others that is/are less costly or which may provide greater enhancement to the reliability, capability or integrity of ATC's transmission facilities and such interconnected transmission or distribution facilities when compared to the estimated cost of the construction and capability of the proposed new, or the proposed modification of, ATC's transmission facilities, while taking into account the environmental considerations, regulatory approvals and the ability to construct the proposed distribution or transmission facilities in a timely and appropriate manner.

**Best Value Planning Scoping Report:** the report jointly developed by ATC and its Customer that documents the decisions leading to the recommended project solution for a given load interconnection request. This report is then use to support project approvals, and regulatory requirements.

**Common Facilities:** those facilities, installed at a joint-use substation, which are substantially used and useful to more than one entity at such substation.

**Customer<sup>23</sup>:** any authorized distribution utility that proposes a new or modified load interconnection with ATC's Transmission System at a nominal voltage level of  $\geq 50$  kV.

**Customer's Interconnection Facilities:** all facilities and equipment, as identified in the D-T IA, that are located between customer load(s) and the Point of Change of Ownership, including any modification, addition, or upgrades to such facilities and equipment necessary to physically and electrically interconnect the load to the Transmission System.

**Distribution-Connected Generation:** is defined as generation facilities connected to ATC Customer distribution voltage feeders or associated with the load (behind the meter) of a specific distribution utility retail customer. Typically distribution connected generation may contain the following fuel types: wind, hydro, land-fill gas, biomass, photovoltaic, or digester gas.

**Distribution – Transmission Interconnection Agreement** is the form of the interconnection agreement between ATC and its Customer at interconnection points that serve Customer load. ATC utilizes an ATC developed Distribution – Transmission Interconnection Agreement template which is filed at FERC and made part of the Midwest FERC Electric Tariff once the interconnection agreement is fully executed.

**Existing Substation:** any substation other than the new interconnection substation at which any single new load interconnection is proposed.

**FERC:** the Federal Energy Regulatory Commission or its successor.

**Good Utility Practice:** any of the practices, methods and acts engaged in or approved by a significant portion of the electric industry during the relevant time period, or any of the practices, methods and acts which, in the exercise of reasonable judgment in light of the facts known at the time the decision was made, could have been expected to accomplish the desired result at a reasonable cost consistent with good business practices, reliability, safety and expedition. Good Utility Practice is not intended to be limited to the optimum practice, method, or act to the exclusion of all others, but rather to be acceptable practices, methods, or acts generally accepted in the region, including those practices required by Federal Power Act Section 215(a)(4). Good Utility Practice includes compliance with Mandatory Reliability Standards.

**Guide:** this ATC published document entitled “Load Interconnection Guide.”

---

<sup>23</sup> Any references to “customer(s)” are intended to include either the distribution utility, their end-use customer that is directly-connected to the transmission system, or both in the sense that the end-use customer's relationship with ATC must be coordinated through the responsible distribution utility.

**Interconnection Facilities:** the physical plant and equipment required to facilitate the transfer of electric energy between two or more entities; including communication equipment, substations and transmission lines.

**Joint-use Substations:** substations in which both the Customer and ATC own facilities.

**Load:** a customer's projected normal peak demand load forecast (in both MW & MVAR) for a minimum 10 years, used by ATC for sizing interconnection facilities.

**Load Interconnection:** the interconnection service provided by ATC at a voltage level  $\geq 50$  kV to a Customer for transformation and/or utilization.

**Load Interconnection Queue:** ATC maintains a listing of load interconnection requests from its Customers for the benefit of both ATC and its Customers. The Load Interconnection Queue is available on the ATC Web site at <http://www.atcllc.com/oasis/liqueue.xls>.

**Mandatory Reliability Standards:** those standards promulgated and approved by NERC as the ERO, or any Regional Entity authorized to do so, as ratified and approved by the FERC that are applicable to ATC and the Customer.

**MISO:** the Midwest Independent Transmission System Operator, Inc. ("MISO"), is the Regional Transmission Organization that administers the MISO FERC Electric Tariff and provides transmission and energy market services over the transmission facilities of its transmission-owning members (including ATC) in interstate commerce.

**Midwest FERC Electric Tariff:** the MISO FERC Electric Tariff under the terms of which open access transmission, energy and operating reserves market and interconnection services are offered, as filed with the FERC, and as amended or supplemented from time to time, or any successor tariff.

**NERC:** the North American Electric Reliability Corporation or its successor organization.

**Network Connection:** an interconnection configured with multiple transmission connections into the load interconnection substation. In addition to the Customer's load, transmission network power may flow through the interconnection facility.

**New Interconnection Substation:** any existing or new substation at which a new load interconnection is proposed.

**Planning Authority:** ATC is the responsible entity that coordinates and integrates transmission facility and service plans, resource plans and protection systems associated with the ATC Transmission System.

**Point of Change of Ownership (PCO):** the point, as set forth in Appendix A to the D-T Interconnection Agreement, where the Customer's Interconnection Facilities connect to the ATC Interconnection Facilities.

**Project Commitment Agreement:** the Project Commitment Agreement (PCA) establishes the commitments by ATC and the Customer when significant resources are required to site, engineer, design, permit, procure, and build the planned interconnection facilities. The PCA will also include any remaining study requirements, the timeline for any necessary regulatory approvals, cost estimates and the preliminary construction schedule.

**Radial Tap Connection:** an interconnection configured with a single transmission connection into the load interconnection substation.

**Tariff:** the Midwest ISO Tariff through which open access transmission service and interconnection service are offered, as filed with the FERC, and as amended or supplemented from time to time, or any successor tariff. Used interchangeably with Midwest ISO ASM Tariff.

**Transmission Facilities:** for the purpose of this Guide, means electric lines and related facilities that are operated at 50 kV and above.

**Transmission Operator:** ATC is the entity responsible for the reliability of the ATC Transmission System. ATC is also the entity that operates or directs the operations of the ATC Transmission System.

**Transmission Owner:** ATC is the entity that owns and maintains the ATC-owned Transmission Facilities.

**Transmission Planner:** ATC is the entity that develops a long-term (generally one year & beyond) plan for the reliability (adequacy) of the interconnected bulk electric transmission systems within its portion of the Planning Authority Area.

**Transmission System:** the facilities owned by ATC subject to the administration of the Midwest ISO that are used to provide energy market, transmission service or wholesale distribution service under the Tariff.

## Appendix A.2 – Index

---

### **A**

Attachment FF-ATCLLC · ii, 3, 8

---

### **B**

Balancing Authority · 8, 22, 37  
Basic Impulse Insulation Level · 16, 23  
Best Value Planning · 3, 7, 8, 15, 18, 23, 35, 37, 45, 46  
breaker · 12, 18, 19, 20, 25, 26, 29, 30, 33  
Breaker Duty · 18  
BVP · 3, 4, 6, 7, 8, 9, 11, 13, 15, 36, 37, 46

---

### **C**

clearances · 25  
common facilities · 12, 13, 34  
Common Facilities · 11, 12, 13, 35, 37  
communications · 21  
coordination · 8, 16, 20, 22, 23, 24, 28

---

### **D**

demarcation · 29, 33  
distribution connected generation · 38  
**Distribution-Connected Generation** · 4, 19, 20, 24, 38

---

### **F**

FERC · 3, 35, 38, 39, 40

---

### **G**

Good Utility Practice · 11, 23, 26, 38  
grounding · 18, 22

---

### **I**

in-service date · 3, 4, 5, 6, 7, 8, 9

Interconnection Agreement · ii, 9, 38, 39

---

**J**

Joint-use Substations · 13, 35, 39

---

**L**

land · 8, 15, 33, 38  
LIRF · 3, 4, 5, 6, 7, 11, 18, 20, 36, 46  
Load Interconnection Request Form · 3, 7, 47, 48, 49  
Loop · 15

---

**M**

maintenance · 3, 8, 12, 13, 26, 28, 32, 33, 34  
metering · 22, 27, 37  
Midwest ISO · 3, 8, 10, 26, 35, 37, 38, 39, 40

---

**N**

network · 6, 10, 20, 39, 46

---

**O**

ownership · 12, 29, 33

---

**P**

PCA · 7, 8, 9, 11, 40  
phase rotation · 16, 25, 34  
power factor · 16, 23  
power quality · 4, 9  
Project Commitment Agreement · 8, 9, 40, 50, 51, 52, 53, 54, 55, 56, 57, 58, 59, 60, 61, 63  
protection · 8, 9, 11, 12, 18, 19, 20, 24, 29, 39

---

**R**

Radial · 15, 21, 33, 40  
ratings · 16, 18, 22, 23, 24, 25  
reactive power · 16  
relay · 12, 19, 26

---

---

**S**

safety · 13, 20, 22, 28, 38  
sectionalizing · 13, 14, 15, 70  
spacing · 25  
switches · 12, 13, 18, 25, 28, 30, 31, 70, 71  
synchronizing · 19, 25

---

**T**

Test Switches · 21  
transformers · 15, 17, 18, 19, 22, 23, 25, 29, 71

---

**U**

un-forecasted load · 7  
**Un-forecasted Load** · 4  
Un-Forecasted Load · 7

---

**V**

voltage · 5, 8, 16, 19, 22, 23, 24, 25, 29, 33, 38, 39, 64

# Appendix B – Load Interconnection Process Overview

## SUMMARY - CUSTOMER & ATC LOAD INTERCONNECTION PROJECT COMPONENTS

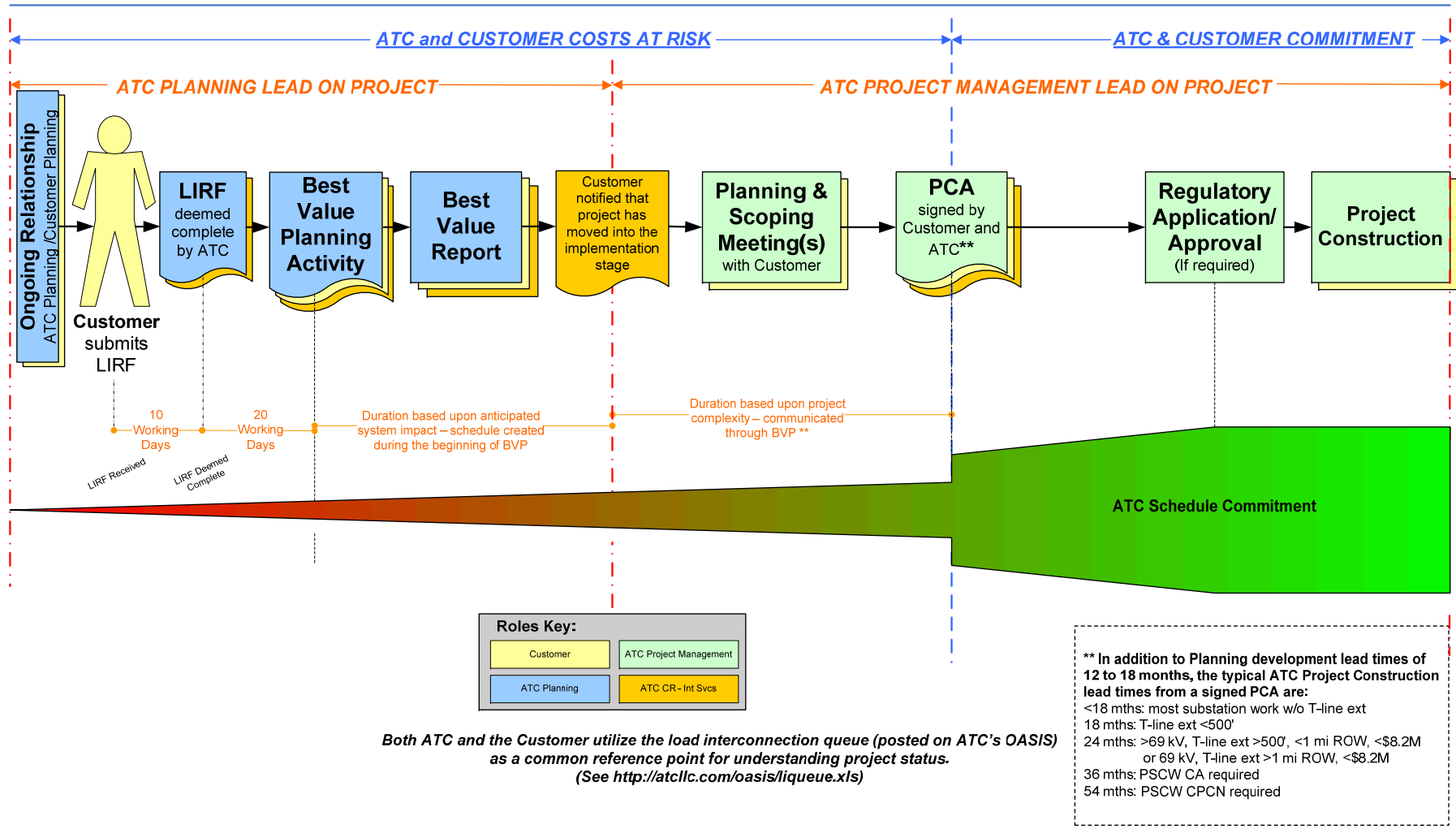

# Appendix B – Load Interconnection Process Overview (continued)

Additional detail showing Best Value Planning Process Map

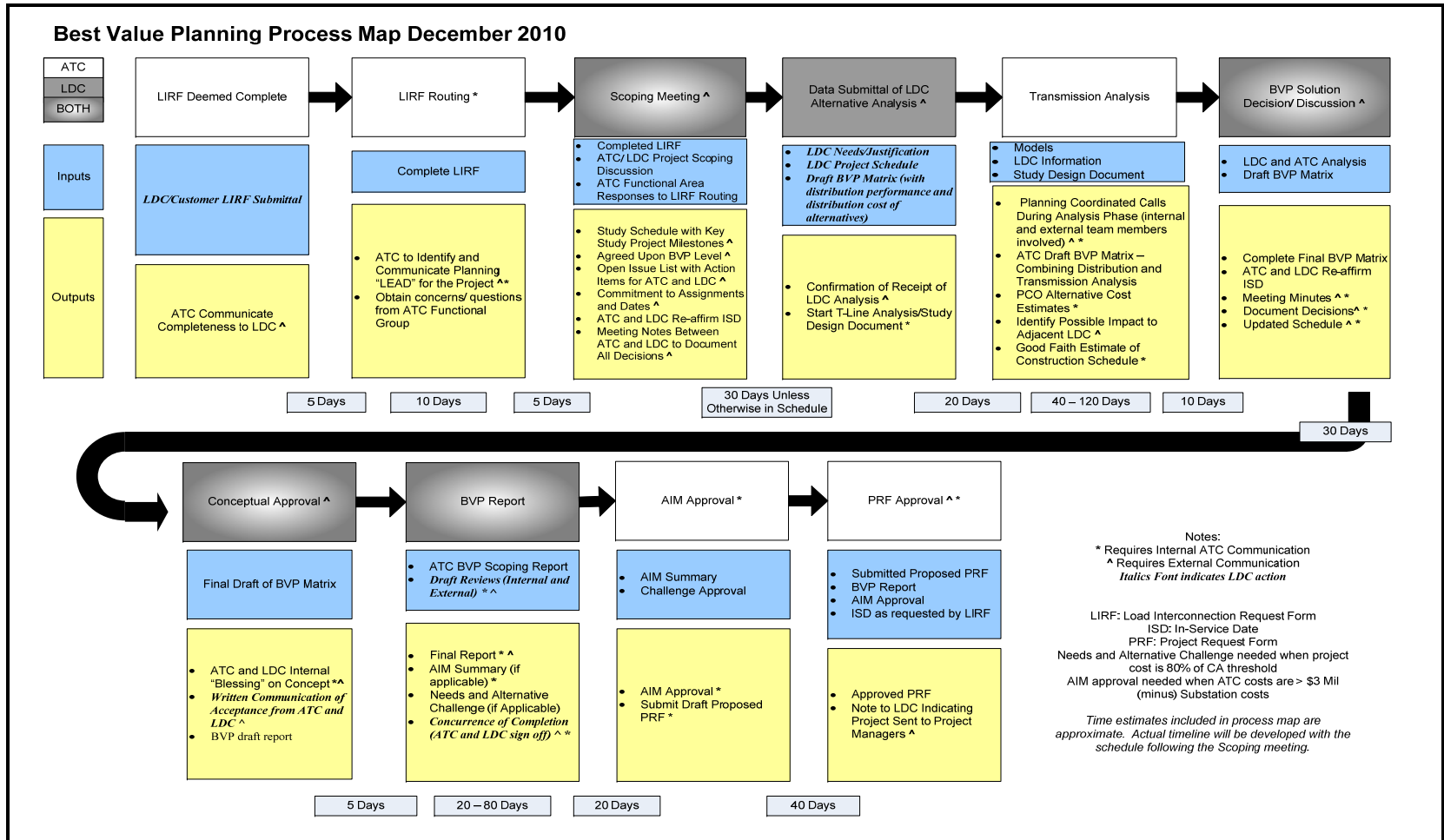

# Appendix C - Best Value Plan Documentation Descriptions

Best Value Planning Level Table

<b>BVP Level*</b>	<b>Explanation**</b>	<b>LDC Information (minimum)</b>	<b>Transmission Analysis</b>	<b>ATC Documentation</b>
1	No or Minimal ATC Capital Work (< \$100,000) and no transmission analysis	Completed LIRF	No planning analysis – internal ATC routing only	Letter stating assessment completed
2	May include a transmission alternative interconnecting load to the transmission line currently serving the local load or assessment of multiple substation configurations	Completed LIRF and LDC distribution assessment	Potential for planning analysis of alternatives including a difference analysis (compared to the base case model) including Category B and C contingencies and possibly different transmission system network and load configurations – amount determined by engineering judgment and team meetings	BVP Scoping Report – describing the pertinent assumptions and assessments that were performed
3	ATC Management approval needed (\$3 million minus substation costs or an abnormal T-D interconnection configuration) or ATC project cost of 80% of the CA threshold or multiple transmission alternatives	Completed LIRF and LDC distribution assessment with at least one viable distribution alternative	Modeling analysis for at least two alternatives including a difference analysis (compared to the base case model) including Category B and C contingencies with different transmission system network and load configurations. Modeling will encompass at least a 10 year planning horizon	BVP Scoping Report
4	ATC needs to file a Certificate of Authority (CA) or Certificate of Public Convenience and Necessity (CPCN) with the PSCW	Completed LIRF and LDC distribution assessment with at least one viable distribution alternative	Modeling analysis for at least two alternatives including a difference analysis (compared to the base case model) including Category B and C contingencies with different transmission system network and load configurations. Modeling will encompass at least a 10 year planning horizon	BVP Scoping Report and support for CPCN or CA filing documentation

\*BVP level and high level schedule will be developed after Scoping Meeting with Customer as seen in Appendix B

\*\*These are typical explanations of BVP types however any given project may change during BVP if the scope of work changes

# Appendix D – Example Load Interconnection Request Form



## Load Interconnection Request Form (LIRF)

LIRF ID # (ATC use only):	
Date Submitted (by LDC):	
Date Received (by ATC):	
Revision:	0

**INSTRUCTIONS:**

1. Complete the LIRF in its entirety (except for non-applicable fields). A PROPOSED ONE-LINE DIAGRAM MUST BE ATTACHED IN PDF OR MICROSOFT WORD FORMAT.
2. If this is a revision to a previously submitted LIRF, edit changes as needed and clearly indicate the change via the corresponding row's checkbox on the left side of this form.
3. ATC will update the queue and assign a LIRF ID Number and a Date Received when a complete LIRF is submitted.
4. Please submit the LIRF to: [T-DLIRFS@atcllc.com](mailto:T-DLIRFS@atcllc.com)

<input type="checkbox"/> Substation Name:		Project Type*: <a href="#">Click here for types</a>	Requested In-Service Date:	
<input type="checkbox"/> Project is confidential	Can project be listed on T-D Queue	<input type="checkbox"/> No <input type="checkbox"/> Yes <input type="checkbox"/> Yes, but list as:		
<input type="checkbox"/> Project is due to an un-forecasted load addition of		MW and		MVAR.

\*If the project type is a transformer replacement, indicate if such a project will include a high voltage protection device replacement as well. If a more detailed description of project type is necessary, provide in the Statement of Need.

**REQUESTER INFORMATION**

<input type="checkbox"/> Requester:		Phone:		Email:	
<input type="checkbox"/> Company					
<input type="checkbox"/> Address:					
<input type="checkbox"/> City:		State:		Zip:	
<input type="checkbox"/> Contact:		Phone:		Email:	

**LOAD INTERCONNECTION INFORMATION**

<input type="checkbox"/>	Location (attach a drawing or a map):		
<input type="checkbox"/>	State:		City:
<input type="checkbox"/>	Has this proposed project been discussed with your Real Estate Department?	<a href="#">Select one (Yes / No)</a>	If so, please provide a contact name:
<input type="checkbox"/>	Will the distribution work require a LDC Certificate of Authority filing with the PSCW?		<a href="#">Select one (Yes/No/ Uncertain)</a>
<input type="checkbox"/>	Predominant nature of load:	<a href="#">Click Here for Types</a>	Please describe any unique aspects of the load
<input type="checkbox"/>	Local Balancing Area before ISD:	<a href="#">Click Here for Types</a>	Local Balancing Area after the ISD: <a href="#">Click Here for Types</a>
<input type="checkbox"/>	Total distribution-connected co-generation or IPP(s): Existing: _____ MW Proposed Additional: _____ MW		
<input type="checkbox"/>	Is this New or Modified distribution connected generator subject to WI PSC119 or MI Generator Interconnection requirements? <a href="#">Select one (Yes / No)</a> Is Application Form Attached? <a href="#">Select one (Yes / No)</a>		
<input type="checkbox"/>	ATC Response required by: _____		
<input type="checkbox"/>	Will a Portable Substation be required as part of this proposed project? <a href="#">Select one (Yes / No)</a>		
<input type="checkbox"/>	<p><b>LOAD CHARACTERISTICS (Describe any of the following that apply):</b></p> <ol style="list-style-type: none"> <li>1) Devices (esp. large motors) that may produce harmonic currents or voltage flicker/imbalance.</li> <li>2) Anticipated needs from ATC (relocations, outages, removals, etc.).</li> <li>3) Proposed transformer protection scheme modifications.</li> <li>4) Existing or proposed distribution networking schemes.</li> <li>5) Details (similar to below) on additional added, replaced, or retired transformers if multiple units are involved.</li> <li>6) Projected load (see page 3)</li> </ol>		
<input type="checkbox"/>	Other _____		

CAUTION: For each submittal please retrieve the most current version of this form from the Oasis at: <http://www.atcllc.com/O.shtm> For questions please contact John Raisler, ATC's Senior Interconnection Specialist, at [jraisler@atcllc.com](mailto:jraisler@atcllc.com) or (262) 832-8723.

# Appendix D – Example Load Interconnection Request Form



## Load Interconnection Request Form (LIRF)

LIRF ID # (ATC use only):

Revision:

### TRANSFORMER SPECIFICATIONS

<input type="checkbox"/>	High Side: Voltage: <input type="text"/> kV	Winding Type: <input type="text"/> delta	Low Side: Voltage: <input type="text"/> kV	Winding Type: <input type="text"/> grounded wye
<input type="checkbox"/>	Continuous/30 min. overload ratings (MVA): <input type="text"/>		Nameplate impedance: <input type="text"/>	
<input type="checkbox"/>	Capacitor banks MVAR & switching (timer, voltage): <input type="text"/>			
<input type="checkbox"/>	Ultimate number of transformers at site: <input type="text"/>			

### STATEMENT OF NEED FOR PROJECT

Include any information or report on the best-value alternative rationale. Attach additional sheets as needed.

JUSTIFICATION OF PROJECT

**CAUTION:** For each submittal please retrieve the most current version of this form from the Oasis at: <http://www.atdcl.com/O.shtml>  
 For questions please contact John Raisler, ATC's Senior Interconnection Specialist, at [jraisler@atdcl.com](mailto:jraisler@atdcl.com) or (262) 832-8723.

# Appendix D – Example Load Interconnection Request Form



## Load Interconnection Request Form (LIRF)

LIRF ID # (ATC use only):

Revision:

### 10-YEAR LOAD PROJECTION

Substation Name:

If the 10-year load forecast for the affected substation(s) has (have) changed since the most recently submitted 10-year load forecast, please complete the following tables. (Hint: Double click on the table to copy and paste your information).

- Loads unchanged from those included in the most recently submitted 10-year load forecast.
  - Loads changed from previous LIRF submittal or previous load forecast.
- Is load:  Typical  Untypical

Projection of Summer Peak Power Requirements (MW) *										
Substation Name	Year									
	1	2	3	4	5	6	7	8	9	10
** Affected SS(s) Name										

Projection of Summer Peak Reactive Power Requirements (MVAR) *										
Substation Name	Year									
	1	2	3	4	5	6	7	8	9	10
** Affected SS(s) Name										
Substation Name										
Calculated Power Factor										

\* NOTE: Please indicate if the Peak Load occurs during a different time of year than the Summer Peak and provide the projected value of that peak in  MW in  MVAR and the projected month the Peak Load may occur. [Click here for Month.](#)

\*\* NOTE: Please indicate what other substation's load forecasts would be affected by the proposed substation. Please provide updated load forecasts for those affected substations.

\*\* NOTE: Please show the projected load of the affected Substations after the addition of the Substation associated with this LIRF.

Additional Comments:

CAUTION: For each submittal please retrieve the most current version of this form from the Oasis at: <http://www.atdcl.com/O.shtm>  
 For questions please contact John Raisler, ATC's Senior Interconnection Specialist, at [raisler@atdcl.com](mailto:raisler@atdcl.com) or (262) 832-8723.

# Appendix E – Example Project Commitment Agreement

PCA#: [Year-Seq#] Amendment#: [Revision]

## PROJECT COMMITMENT AGREEMENT

---

This PROJECT COMMITMENT AGREEMENT (PCA) between [Name of LDC], a [Double Click for Options] (Local Distribution Company or LDC) and American Transmission Company LLC, a Wisconsin limited liability company, and ATC Management Inc. (collectively, ATC) for a project known as [Project name and scope] is effective on the latest date signed by the authorized representatives of each party. ATC and the LDC each may be referred to as a "Party" or collectively as the "Parties."

### ARTICLE I

#### BACKGROUND AND PURPOSE

ATC is a public utility and transmission company under the laws of the State of Wisconsin and owns, operates, and maintains an electric transmission system and provides transmission service, including the interconnection of substations owned by others. ATC operates its transmission system under provisions of the open access transmission and energy markets tariff (TEMT) of the Midwest Independent Transmission System Operator, Inc. (MISO).

The LDC owns, operates, and maintains an electric distribution system that does or will provide power to end-use customers in part via an interconnection to ATC's transmission system.

As the project requestor, [Double Click for Options] wishes to initiate a project that requires additions and/or modifications to the other Party's system or facilities. The two Parties will collaborate in the design, construction and performance of the services necessary for the construction of the affected facilities.

The purpose of this PCA is (1) to identify the initial conceptual design and configuration of the affected facilities and designations of the common facilities; (2) to establish a commitment by both Parties to make a good faith effort to meet the project in-service date set forth in Exhibit A hereto; and (3) to set forth the obligation for both Parties to consult with each other before terminating this Agreement.

### ARTICLE II

#### SCOPE AND SCHEDULE

The work provided for under this PCA shall commence and be completed according to the scope and schedule attached as Exhibit A to this PCA.

The Parties shall jointly coordinate scope and schedule adjustments as necessary and mutually agreeable. After this PCA has been executed, any Party's request to change the in-service date of the project and the other Party's subsequent answer must be made in accordance with Article IV. This PCA will be amended and signed for changes to the in-service date of 90 days or more or other minor changes. A revised PCA superseding and replacing this PCA will be signed for any substantial changes in project scope.

CAUTION: This document must be submitted with Part 2 of the PCA unless ATC is creating the PCA, whereas the interconnection Administrator will create Part 1. The PCA is maintained by ATC. Any hard copy reproductions should be verified against ATC's on-line system for current revisions.

DRAFT [Today's Date] PCA [PCA# (ISA)] [Project Name]  
PCA template version dated 9/22/09

Page 1

# Appendix E – Example Project Commitment Agreement (continued)

## ARTICLE III

### TERMS OF AGREEMENT

The work to be performed under this PCA will be performed in accordance with the standards set forth in the Interconnection Agreement between the Parties, except to the extent superseding standards are included in this PCA.

The Parties may, by written agreement, cancel or suspend the project with each Party being responsible for its own incurred costs up to the date of cancellation or suspension without any invoicing of costs between the Parties.

Any dispute that may arise between the Parties during the project development and interconnection process regarding schedule, scope, cost or any other matter, including a request for reimbursement of costs by one Party resulting from the other Party's unilateral cancellation or delay of the project, by more than 90 days, shall be subject to the Dispute Resolution procedures of the Interconnection Agreement.

This PCA incorporates by reference and shall be governed by the terms and conditions of the ATC business practices noted in Exhibit C. In the event of any inconsistency or conflict between this PCA and an ATC business practice, the PCA shall govern solely with respect to the services provided or contemplated hereunder.

## ARTICLE IV

### NOTICES

All notices required hereunder shall be given in writing and addressed or delivered to the representative(s) specified below. Notices shall be deemed received (i) upon delivery, when personally delivered or sent via overnight courier; (ii) upon receipt, when sent via certified mail, return receipt requested; or (iii) upon receipt confirmation from the receiving party when sent via email.

*Delete: Company, Address, City, State and Zip once text is entered.*

Notices to the LDC:

Company: [Name of LDC, Copy from 1<sup>st</sup> Paragraph]

Attn: [LDC Contact First/Last Name]

Address: [P.O. Box (if applicable), then mailing address]

City, State, Zip: [City, State, and Zip Code]

Notices to ATC:

American Transmission Company

Attn: John Raisler

P.O. Box 47

W234 N2000 Ridgeview Pky, Court

Waukesha, WI 53188-1022

CAUTION: This document must be submitted with Part 2 of the PCA unless ATC is creating the PCA, whereas the Interconnection Administrator will create Part 1. The PCA is maintained by ATC. Any hard copy reproductions should be verified against ATC's on-line system for current revisions.

DRAFT [Today's Date] PCA [PCA# (ISA)] [Project Name]  
PCA template version dated 9/22/09

Page 2

# Appendix E – Example Project Commitment Agreement (continued)

This PCA supersedes and replaces in its entirety PCA [#], dated [Copy date from page 3 of previous PCA] signed by, [Enter named persons from page 3 of the previous PCA], for the project titled [Enter Project name and scope from paragraph 1 of the previous PCA.]

**THIS AGREEMENT IS ENTERED INTO BY THE DULY AUTHORIZED REPRESENTATIVES OF THE PARTIES WHOSE SIGNATURES ARE SET FORTH BELOW.**

AMERICAN TRANSMISSION COMPANY LLC  
By its Corporate Manager, ATC Management Inc.

By: \_\_\_\_\_  
Title: [Name of ATC Representative]  
Date: [Full Title]  
Date: \_\_\_\_\_

[Name of LDC, Copy from 1<sup>st</sup> Paragraph]  
\_\_\_\_\_  
By: \_\_\_\_\_  
Title: \_\_\_\_\_  
Date: \_\_\_\_\_

*CAUTION: This document must be submitted with Part 1 of the PCA unless ATC is creating the PCA, whereas the Interconnection Administrator will create Part 1. The PCA is maintained by ATC. Any hard copy reproductions should be verified against ATC's on-line system for current revisions.*

DRAFT [Today's Date] PCA [PCA# (ISA)] [Project Name]  
PCA template version dated 10/15/00

# Appendix E – Example Project Commitment Agreement (continued)

Development Instructions for PCA Template (8/1/07)

1. Replace brackets and green text with project specific information. Keep font at Arial size 11 to stay consistent throughout the document.
2. Do not fill in the PCA/Amendment #'s.
3. If you do not have attachments for Exhibits B1-B3 leave in the template text. If blank remove Exhibit B4.
4. Update the footer filename to minimize confusion of different draft versions. The Interconnection Services Administrator (ISA) will update the filename to include the PCA # during final processing.
5. Once the customer confirms acceptance of the final draft, send that confirmation, the final draft PCA, and a cover email with customer type and contact information to the ISA.
6. The ISA will delete these instructions, prepare Part 1 (if being prepared by ATC) of the PCA, and route the complete PCA (parts 1 and 2 together) for signatures.

PCA #: [Entered by ISA] Amendment#: [Entered by ISA]

### Exhibit A – Preliminary Project Scope and Schedule

**Project Title:** [Project name and scope (e.g. ABC Substation Load Interconnection)]

**ATC Contact Person:** [Full Name]      **Phone:** [000-000-0000]      **Email:** [jdoe@atcllc.com]

**LDC Contact Person:** [Full Name]      **Phone:** [000-000-0000]      **Email:** [jdoe@atcllc.com]

**Project Location (including substation name, if applicable):** [Description]

**In-Service Date:** [00-00-0000]      **Voltage:** [69/138] kV

#### ATC PROJECT DETAILS

**Regulatory Approvals Required:** [Enter "None" if not applicable]

**Permits Required:** [Enter "None" if not applicable]

**Public Outreach Plan:** [Enter "None" if not applicable]

**Scope of Work Resultant from Requestor's Project:** [Enter scope]

**Budgetary Estimate and Schedule:** (Add, remove, or revise table items as appropriate.)

Activity	Est. Start Date	Est. Cost
Pre-certification	[00-0000]	\$0
Engineering	[00-0000]	\$0
Siting and ROW work	[00-0000]	\$0
Equipment procurement	[00-0000]	\$0
Construction	[00-0000]	\$0
[Other, delete line if not needed]	[00-0000]	\$0
<b>Total</b>	-	\$ 0.00

CAUTION: This document must be submitted with Part 1 of the PCA unless ATC is creating the PCA, whereas the Interconnection Administrator will create Part 1. The PCA is maintained by ATC. Any hard copy reproductions should be verified against ATC's on-line system for current revisions.

DRAFT [Today's Date] PCA [PCA# (ISA)] [Project Name]  
PCA template version dated 10/15/09

# Appendix E – Example Project Commitment Agreement (continued)

**LDC PROJECT DETAILS**

**Regulatory Approvals Required:** [Enter "None" if not applicable]

**Permits Required:** [Enter "None" if not applicable]

**Public Outreach Plan:** [Enter "None" if not applicable]

**Scope of Work Resultant from Requestor's Project:** [Enter scope]

**Budgetary Estimate and Schedule:** *(Add, remove, or revise table items as appropriate.)*

Activity	Est. Start Date	Est. Cost
[Enter line item]	[00-0000]	\$0
[Enter line item]	[00-0000]	\$0
[Enter line item]	[00-0000]	\$0
Total	-	\$ 0.00

CAUTION: This document must be submitted with Part 1 of the PCA unless ATC is creating the PCA, whereas the Interconnection Administrator will create Part 1. The PCA is maintained by ATC. Any hard copy reproductions should be verified against ATC's on-line system for current revisions.

DRAFT [Today's Date] PCA [PCA# (ISA)] [Project Name]  
PCA template version dated 10/15/00

Page 5

# Appendix E – Example Project Commitment Agreement (continued)

---

## Exhibit B – Project Attachments

---

**Project Title:** [Copy from Page 4]

**Please find attached:**

- Exhibit B1 – One-Line Diagram
- Exhibit B2 – Project Schedule(s)
- Exhibit B3 – Best Value Planning Report, if applicable
- Exhibit B4 – Miscellaneous Attachments – [List names of any additional attachments]

*CAUTION: This document must be submitted with Part 1 of the PCA unless ATC is creating the PCA, whereas the Interconnection Administrator will create Part 1. The PCA is maintained by ATC. Any hard copy reproductions should be verified against ATC's on-line system for current revisions.*

*DRAFT [Today's Date] PCA [PCA# (ISA)] [Project Name]  
PCA template version dated 10/15/00*

Page 6

# Appendix E – Example Project Commitment Agreement (continued)

---

## Exhibit B1 – One-Line Diagram

---

**Project Title:** [Copy from Page 4]

This page intentionally left blank.

*CAUTION: This document must be submitted with Part 1 of the PCA unless ATC is creating the PCA, whereas the Interconnection Administrator will create Part 1. The PCA is maintained by ATC. Any hard copy reproductions should be verified against ATC's on-line system for current revisions.*

*DRAFT [Today's Date] PCA [PCA# (ISA)] [Project Name]  
PCA template version dated 10/15/09*

Page 7

# Appendix E – Example Project Commitment Agreement (continued)

## Exhibit B2 – Project Schedule(s)

---

**Project Title:** [Copy from Page 4]

This page intentionally left blank.

*CAUTION: This document must be submitted with Part 1 of the PCA unless ATC is creating the PCA, whereas the Interconnection Administrator will create Part 1. The PCA is maintained by ATC. Any hard copy reproductions should be verified against ATC's on-line system for current revisions.*

*DRAFT [Today's Date] PCA [PCA# (ISA)] [Project Name]  
PCA template version dated 10/15/00*

Page 8

# Appendix E – Example Project Commitment Agreement (continued)

---

## **Exhibit B3 – Best Value Planning Report, if applicable**

---

**Project Title:** [Copy from Page 4]

This page intentionally left blank.

*CAUTION: This document must be submitted with Part 1 of the PCA unless ATC is creating the PCA, whereas the Interconnection Administrator will create Part 1. The PCA is maintained by ATC. Any hard copy reproductions should be verified against ATC's on-line system for current revisions.*

*DRAFT [Today's Date] PCA [PCA# (ISA)] [Project Name]  
PCA template version dated 10/15/00*

Page 9

# Appendix E – Example Project Commitment Agreement (continued)

---

## Exhibit B4 – Miscellaneous Attachments

---

**Project Title:** [Copy from Page 4]

This page intentionally left blank.

*CAUTION: This document must be submitted with Part 1 of the PCA unless ATC is creating the PCA, whereas the Interconnection Administrator will create Part 1. The PCA is maintained by ATC. Any hard copy reproductions should be verified against ATC's on-line system for current revisions.*

*DRAFT [Today's Date] PCA [PCA# (ISA)] [Project Name]  
PCA template version dated 10/15/00*

Page 10

# Appendix E – Example Project Commitment Agreement (continued)

## Exhibit C – Applicable ATC Business Practices

Project Title: [Copy from Page 4]

As checked below, the terms of the following ATC Business Practices<sup>1</sup> shall apply to the project defined in Exhibit A, with the additional qualifications noted here. Any noted costs assigned from one party to the other will be subject to possible tax liability implications associated with making this contribution in aid of construction (CIAC). ATC's Business Practices are available for review on ATC's Internet website: [http://www.atcllc.com/CR\\_bp.shtml](http://www.atcllc.com/CR_bp.shtml)

None of the listed ATC Business Practices Apply

Asset Acquisition

The subject project of this PCA is related to an associated asset acquisition from [Enter Transferring Entity Name] under terms defined by a separate Asset Purchase Agreement.

Capacitor Bank Installations on Distribution Systems for Transmission Benefit

[Enter ATC or LDC] shall be responsible for the [ \$? , lease or purchase/install? ] costs associated with the distribution capacitor bank installation described in Exhibit A.

Will a switching and/or operating agreement be required?  Yes  No Describe: [Enter description]

Coordination of Balancing Authority Metering Boundary Modifications

- A. Affected Balancing Authorities (BA): [First BA Name] and [Second BA Name]
- B. Entity responsible for ATC BA metering work costs: [Entity Name]
- C. ATC scope of work specifically for BA boundary metering purposes: [BA metering scope]
- D. Estimated ATC engineering & construction cost for BA metering scope of work: \$[Cost]
- E. Applicable income tax as of the date of this agreement @ [Tax rate] %: \$[Tax]
- F. <sup>2</sup>Estimated BA metering cost (F = D + E): \$[Cost]

Elective Load Interconnection Facilities

- A. Requested Interconnection Facilities Scope of Work: [Enter scope as consistent with Exhibit A]
- B. Estimated Requested Interconnection Facilities Cost: \$[Cost]
- C. Standard Interconnection Facilities Scope of Work: [Enter hypothetical scope per ATC standards]
- D. Estimated Standard Interconnection Facilities Cost: \$[Cost]
- E. Requested – Standard Interconnection Facilities Cost (E = B – D): \$[Cost]
- F. Applicable income tax as of the date of this agreement @ [Tax rate] %: \$[Tax]
- G. <sup>2</sup>Estimated Elective Interconnection Facilities Cost (G = E + F): \$[Cost]

CAUTION: This document must be submitted with Part 1 of the PCA unless ATC is creating the PCA, whereas the Interconnection Administrator will create Part 1. The PCA is maintained by ATC. Any hard copy reproductions should be verified against ATC's on-line system for current revisions.

DRAFT [Today's Date] PCA [PCA# (ISA)] [Project Name]  
PCA template version dated 10/15/09

Page 11

# Appendix E – Example Project Commitment Agreement (continued)

- Elective Undergrounding**
  - A. Scope of facilities for Elective Undergrounding: [Enter scope]
  - B. Estimated ATC engineering & construction cost for Elective Undergrounding: \$[Cost]
  - C. Applicable income tax as of the date of this agreement @ [Tax rate] %: \$[Tax]
  - D. <sup>2</sup>Estimated Elective Undergrounding cost (D = B + C): \$[Cost]
  
- Electrical Underbuild and Attachment to ATC Transmission Facilities** (A Request for Pole Attachment must also be completed for any new or modified attachments to existing ATC transmission facilities.)
  - A. Will a new or revised Attachment Agreement between ATC and the LDC be necessary? [Yes/No]
  - B. Scope of make-ready or incremental under- or overbuild work: [Enter scope]
  - C. Estimated [ATC/LDC] ATC engineering & construction cost for electrical underbuild and attachment work: \$[Cost]
  - D. Applicable income tax as of the date of this agreement @ [Tax rate] %: \$[Tax]
  - E. <sup>2</sup>Estimated total cost from [ATC/LDC] to [ATC/LDC] for electrical underbuild and attachment work (E = C + D): \$[Total cost]
  
- Joint Use Substations – Common Facilities – Cost Responsibility for Improvements, Modifications, Maintenance, etc.**
  - A. Common Facilities Owner: [Enter Name]
  - B. Common Facilities Improvements initiator: [Enter Initiator]
  - C. Scope of new or improved Common Facilities: [Enter scope]
  - D. Scope of Common Facilities Improvements Assignable to the initiator: [Enter scope]
  - E. <sup>3</sup>Common Facilities Owner's estimated cost of Common Facilities Improvements Assignable to the initiator: \$[Cost]
  
- Line Relocation Cost Allocation** (Check this box only if relocation of transmission facilities is a component of a larger project as described in Exhibit A. A separate Transmission Facility Relocation Agreement may still be required in addition to this PCA.)

Scope of facilities to be relocated: [Enter scope]
  
- Substation "Make Ready" Cost Reimbursement**
  - A. Make Ready work initiator: [Initiator Name]
  - B. Scope of Make Ready Work: [Enter Scope]
  - C. Estimated engineering & construction Make Ready Costs: \$[Cost]
  - D. Applicable income tax as of the date of this agreement @ [tax rate] %: \$[Cost]
  - E. <sup>2</sup>Estimated total cost of Make Ready work (E = C + D): \$[Cost]

*CAUTION: This document must be submitted with Part 1 of the PCA unless ATC is creating the PCA, whereas the Interconnection Administrator will create Part 1. The PCA is maintained by ATC. Any hard copy reproductions should be verified against ATC's on-line system for current revisions.*

*DRAFT [Today's Date] PCA [PCA# (ISA)] [Project Name]  
PCA template version dated 10/15/00*

Page 12

# Appendix E – Example Project Commitment Agreement (continued)

**Voltage Conversion – Cost Allocation**

**Load Bridging for Transmission Related Work – Cost Responsibility for Temporary Load Bridging Plan.**

- A. Who Initiated The Project Work That Requires The Temporary Load Bridging Plan?: **[Enter Initiator]**
- B. Scope of Work for Temporary Load Bridging Plan: **[Enter scope]**
- C. Estimated cost of Temporary Load Bridging Plan assignable to the initiator: **[\$[Cost]]**

**Substation Soil Groundwater Management Practice – Cost Responsibility for Environmental Work Associated With Managing Excavated Soils and Groundwater Generated From Substation Construction and Maintenance Activities.**

- A. Work Location - **[Enter Substation Name]**
- B. Who Initiated The Substation Work That Requires The Environmental Work?: **[Enter Initiator]**
- C. Who Owns the Substation?
  - ATC Owned Substation – Environmental Work is to Follow the ATC Substation Soil Groundwater Management Practice ENV WM 04 (Please refer to ATC environmental project manager for the latest version of this document).
  - LDC Owned Substation - Environmental Work is to Follow the LDC Substation Soil Groundwater Management Plan. (Please refer to the LDC environmental contact for guidance.)
- Scope of Environmental Work associated with this project (Limited to Sampling & Disposal Cost): **[Enter Scope of work]**
- ATC Environmental Scope of Work: **[Enter scope]**
- LDC Environmental Scope of Work: **[Enter scope]**
- D. Estimated cost of Environmental Work assignable to the initiator: **[\$[Cost]]**
  - Estimated Cost of ATC Environmental Work: **[\$[Enter Cost]]**
  - Estimated Cost of LDC Environmental Work: **[\$[Enter Cost]]**

<sup>1</sup> Versions of Business Practices in effect at the time this PCA is executed shall apply. Copies of archived Business Practices are available upon request to ATC's Interconnection Administrator.

<sup>2</sup> Any payment transaction ≥ \$ 25,000 between ATC and an affiliate must be reported to the PSCW.

<sup>3</sup> Income tax is not applicable to payment between affiliates for Common Facilities work.

*CAUTION: This document must be submitted with Part 1 of the PCA unless ATC is creating the PCA, whereas the Interconnection Administrator will create Part 1. The PCA is maintained by ATC. Any hard copy reproductions should be verified against ATC's on-line system for current revisions.*

DRAFT [Today's Date] PCA [PCA# (ISA)] [Project Name]  
PCA template version dated 10/15/00

Page 13

# Appendix F – Interconnection Configurations

















	Existing	Proposed for present or ultimate installation	Space for future (>10 yrs) installation
Circuit breaker			
Disconnect switch (switch with horns typical).			
Disconnecting device with sufficient capability to break line charging current (switch with whips typical).			
Disconnect switch with sufficient capability for loop-splitting on network lines or load-breaking on radial lines (switch with interrupter typical).			
Interrupting device sufficient for power transformer protection (circuit switcher typical) including air-break switch <sup>1</sup> .			
Power transformer			

Figure F.1: Load Interconnection Configuration Diagrams Symbol Key

<sup>1</sup>. For 69 kV applications, If the interrupting device is a fuse, a series switch capable of breaking transformer magnetizing current is needed and low voltage device(s) is(are) needed for breaking load.

# Appendix F – Interconnection Configurations (Continued)

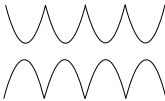
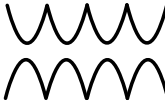
## Configuration A

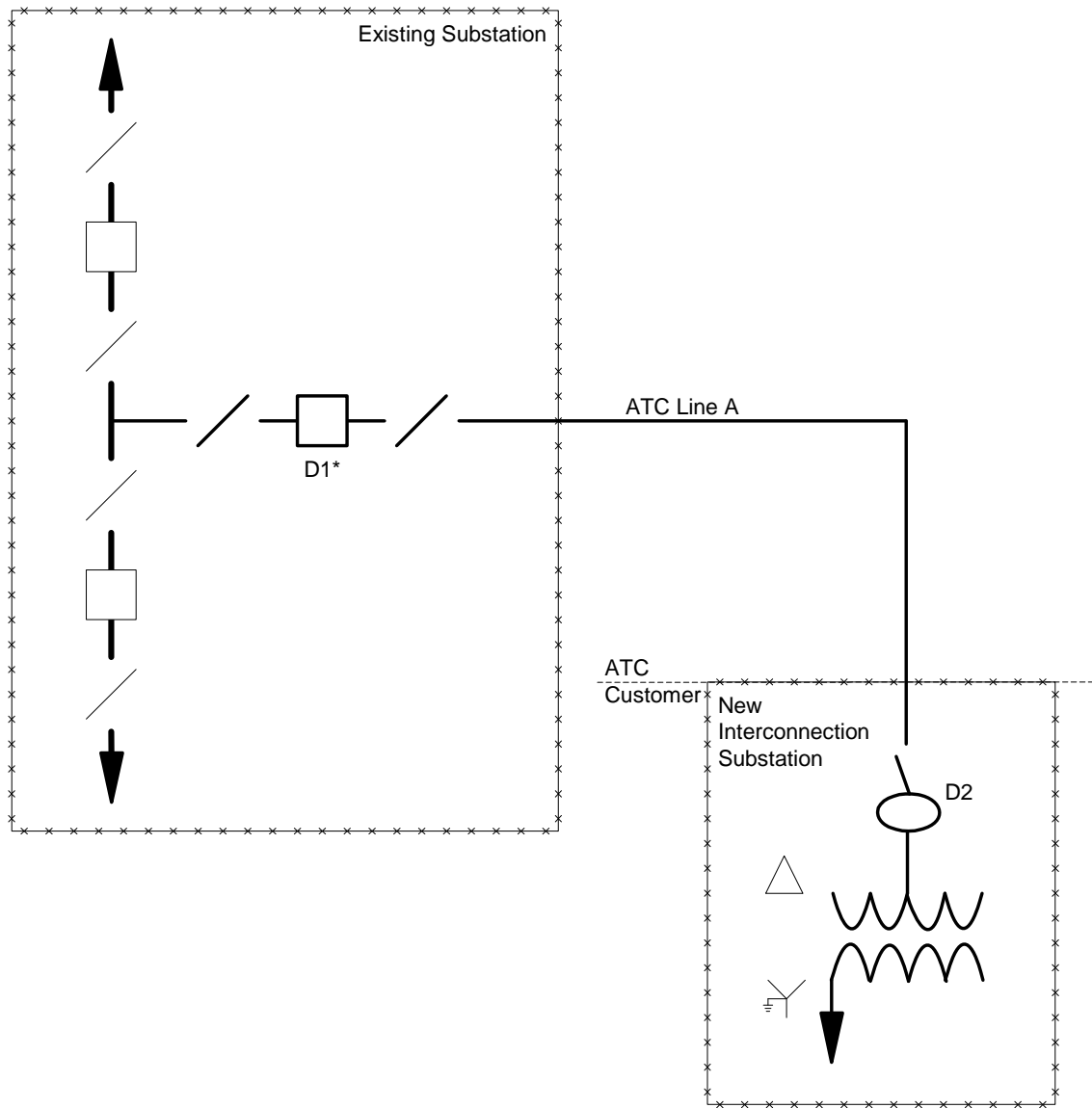

- \* This line terminal breaker is not necessarily required if either of the following is true:
- 1) The radial line is terminated into a ring bus or breaker-and-a-half configuration.
  - 2) The length of the tap from the mainline to the load interconnection substation is short enough that transmission exposure is minimal and the Customer's transformer protective device is sufficient by itself.

Figure F.2: Load Interconnection Configuration A

# Appendix F – Interconnection Configurations (Continued)

## Configuration B

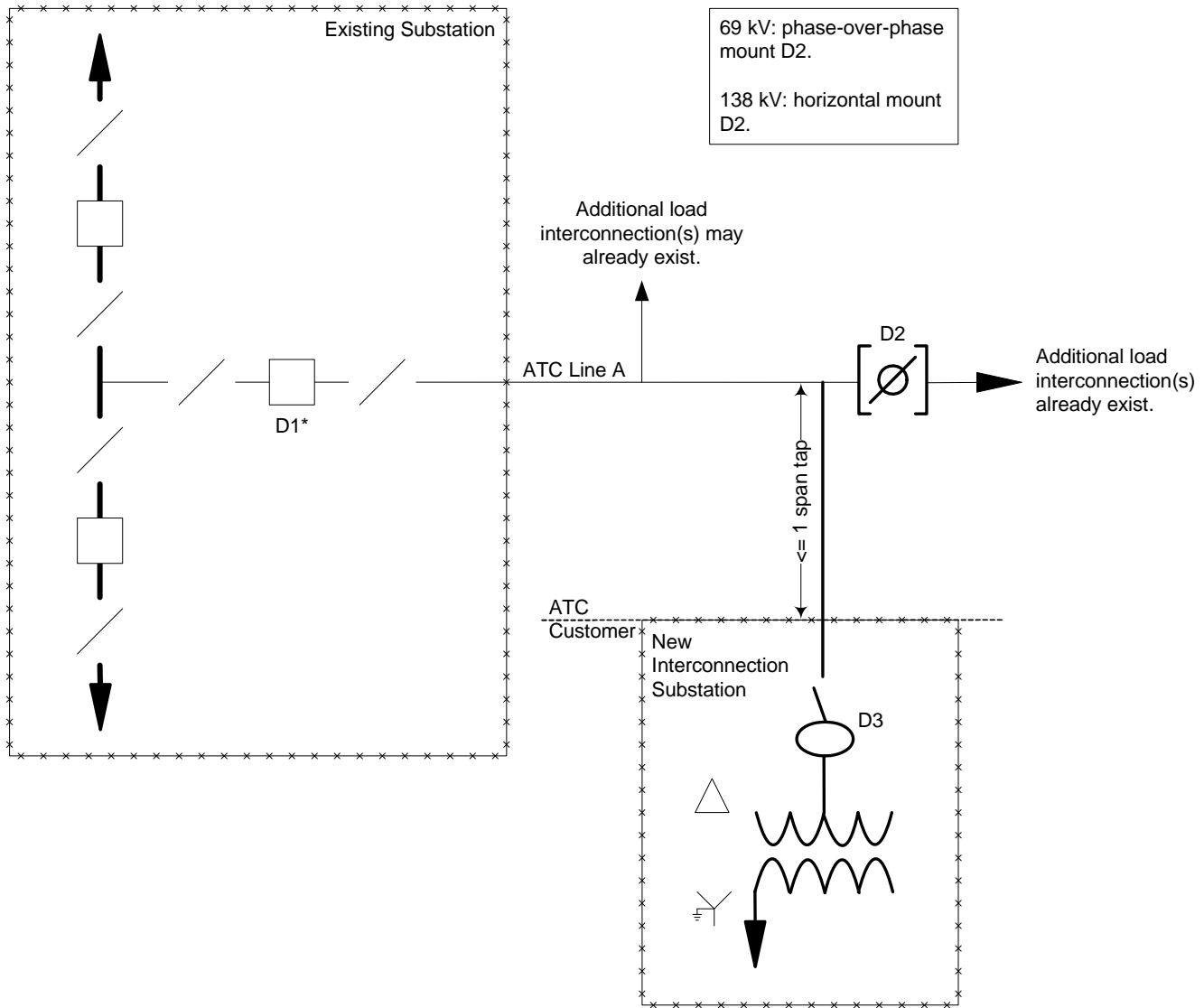

\* This line terminal breaker is not necessarily required if the radial line is terminated into a ring bus or breaker-and-a-half configuration.  
 Note: Switch D2 is needed only if it is greater than 1 mile to the next substation.

Figure F.3: Load Interconnection Configuration B

# Appendix F – Interconnection Configurations (Continued)

## Configuration C

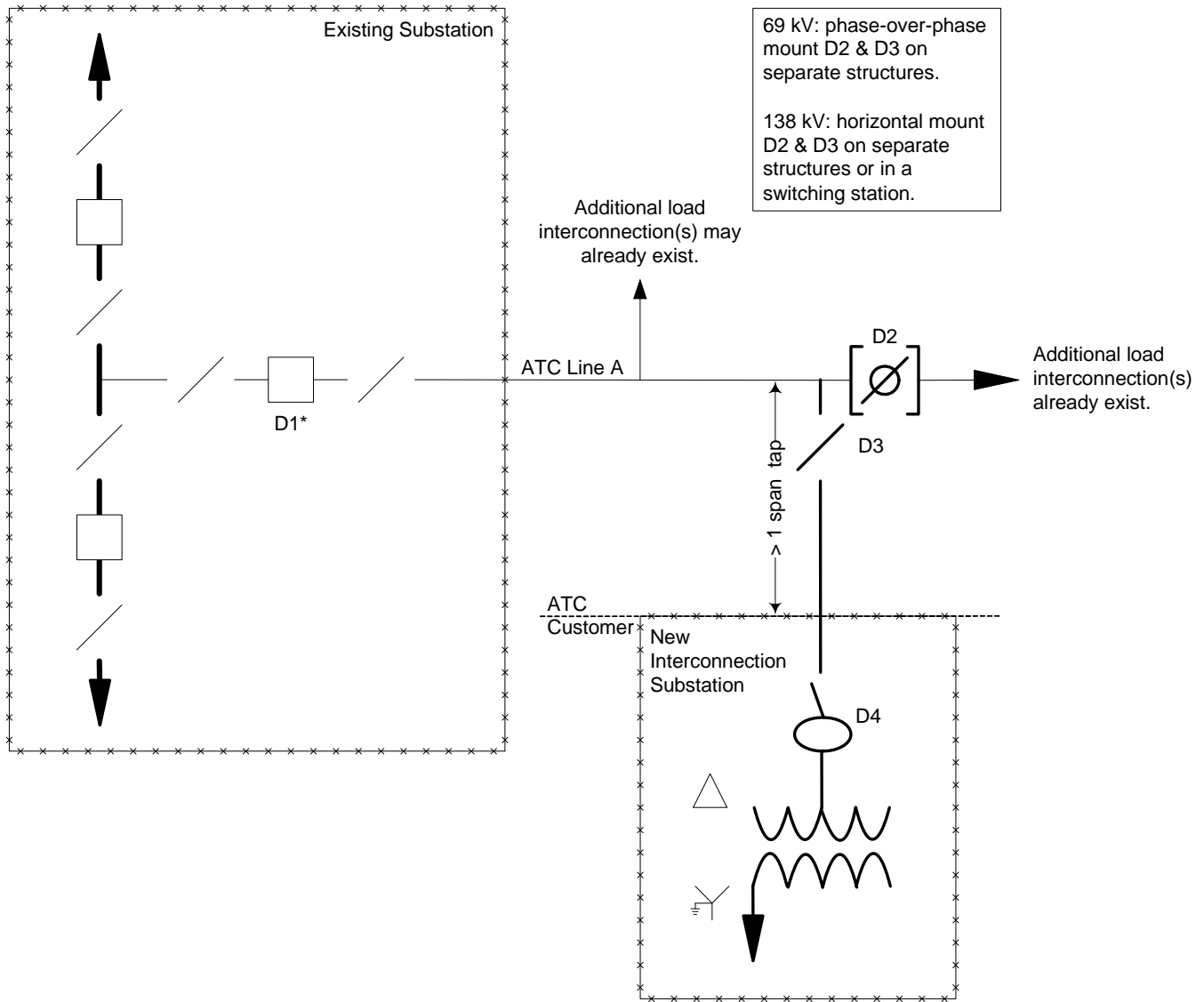

\* This line terminal breaker is not necessarily required if the radial line is terminated into a ring bus or breaker-and-a-half configuration.

Figure F.4: Load Interconnection Configuration C

# Appendix F – Interconnection Configurations (Continued)

## Configuration D

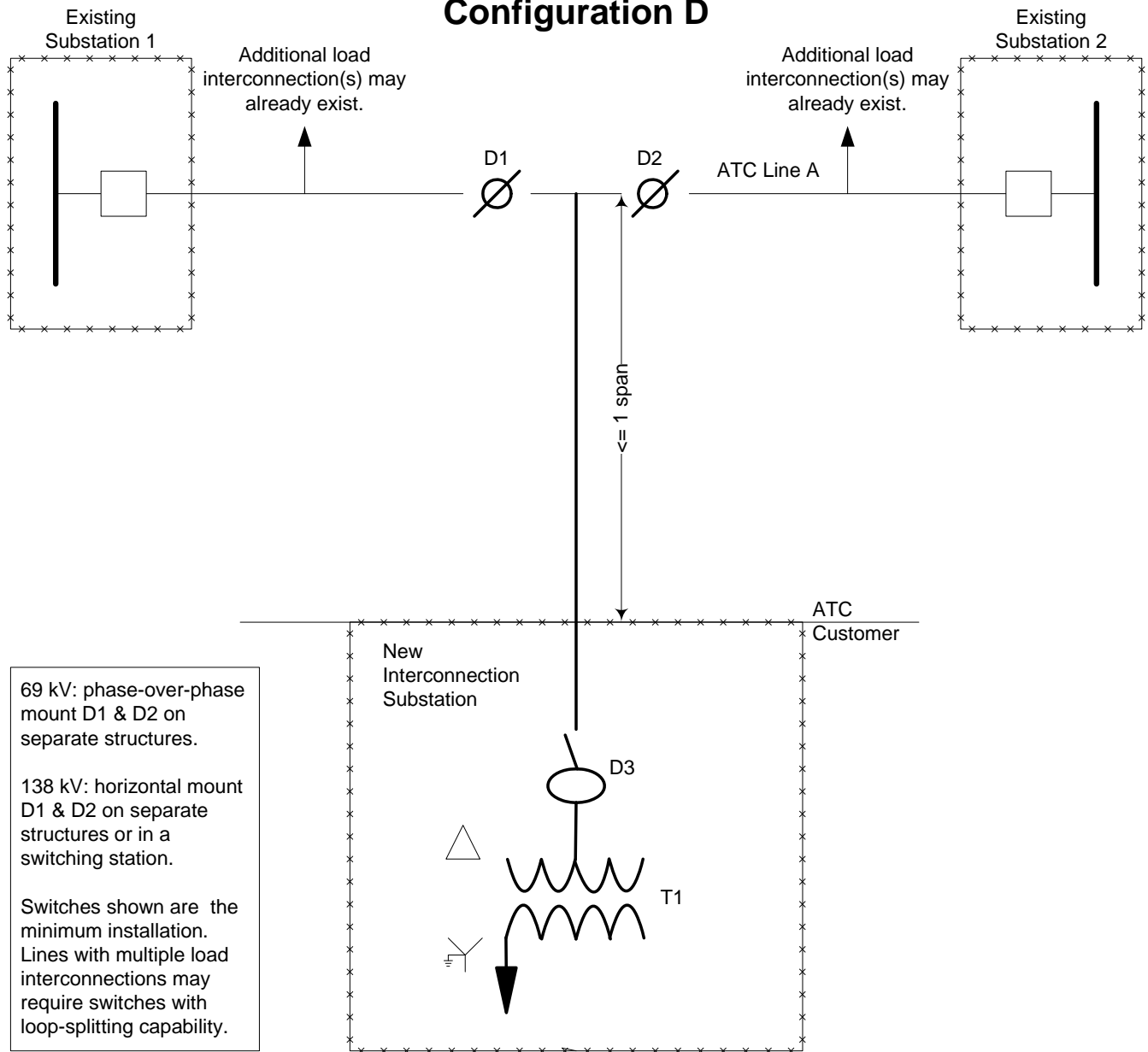

Figure F.5: Load Interconnection Configuration D

# Appendix F – Interconnection Configurations (Continued)

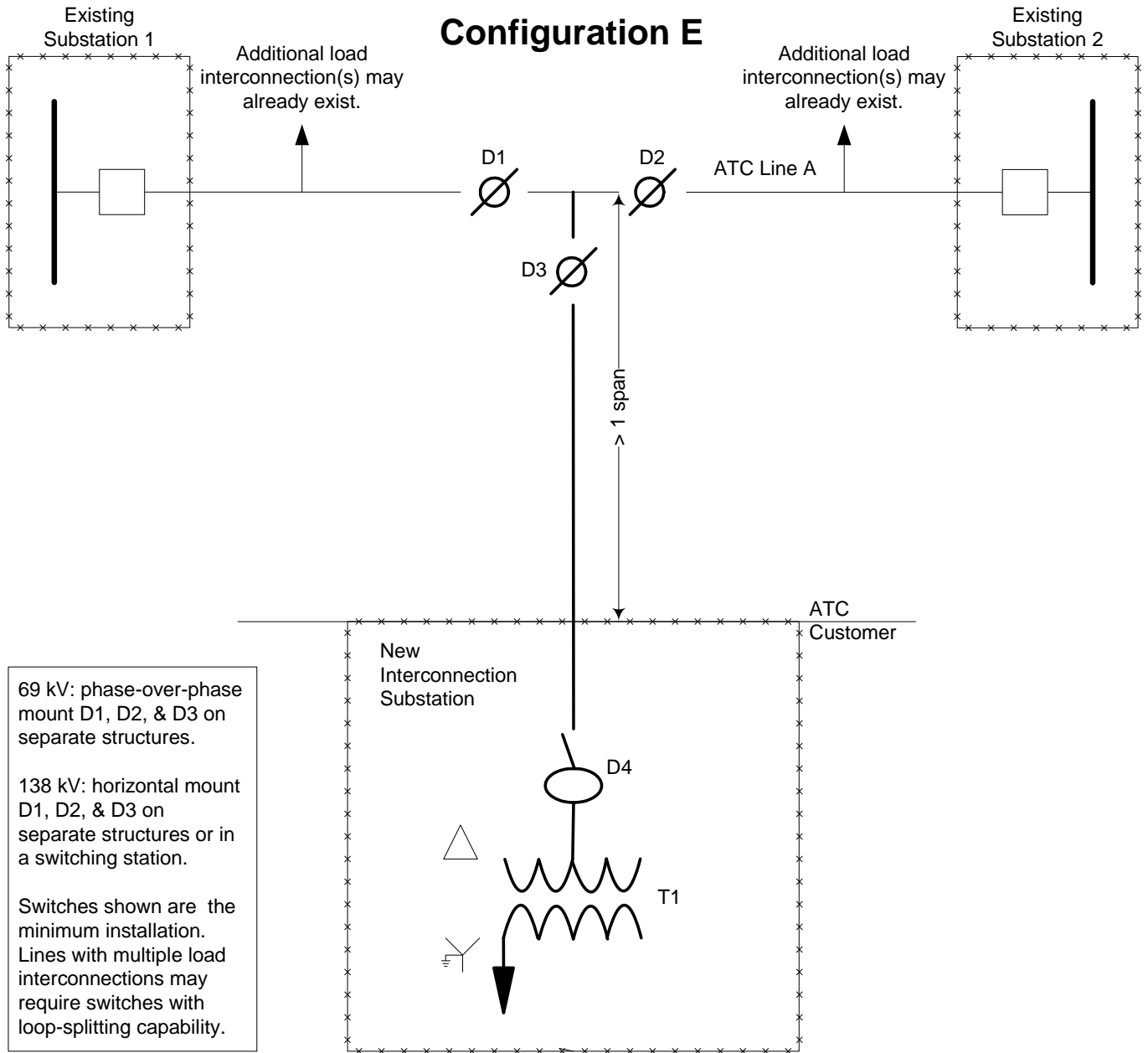

Figure F.6: Load Interconnection Configuration E

# Appendix F – Interconnection Configurations (Continued)

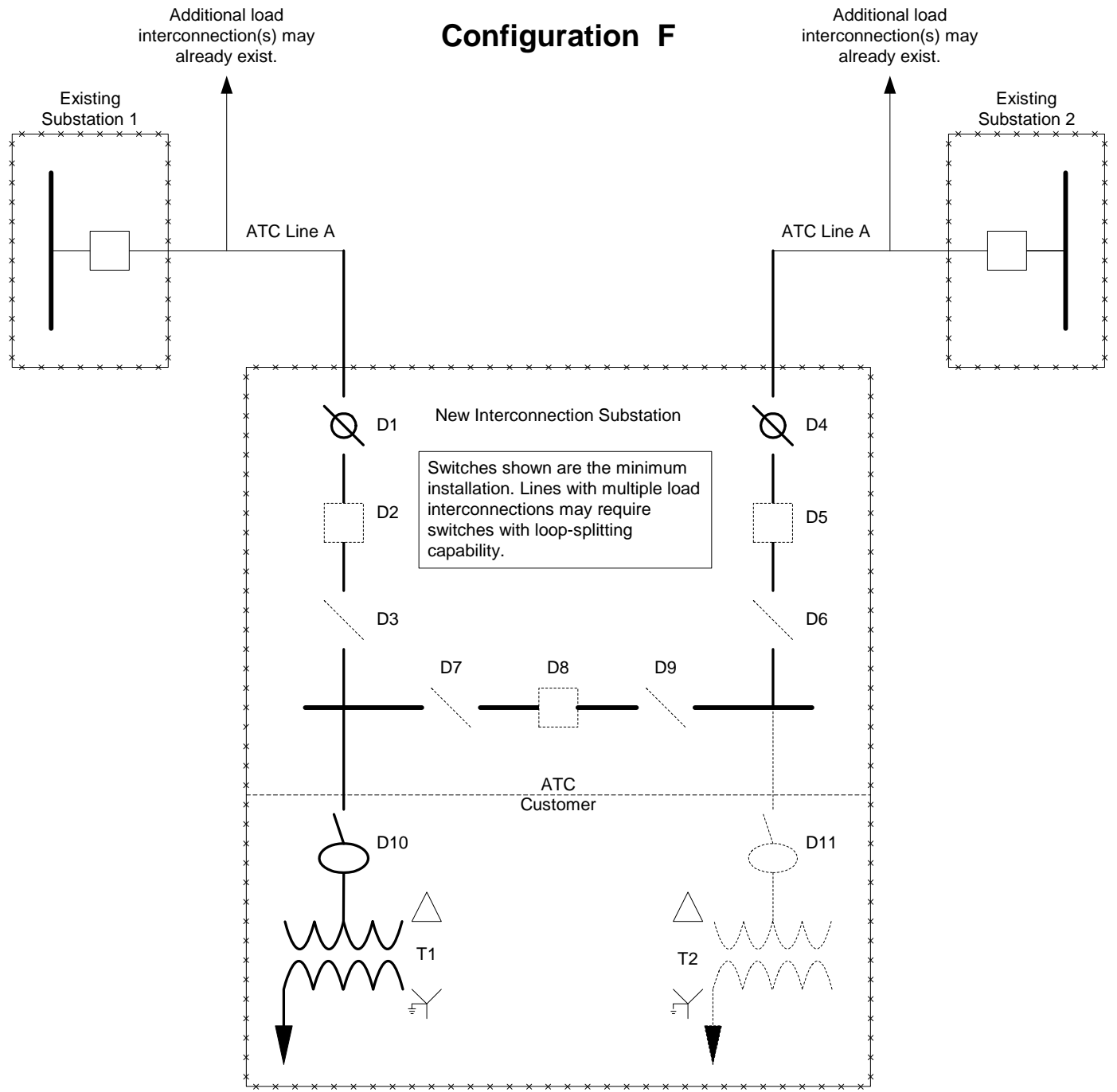

Figure F.7: Load Interconnection Configuration F

Note: For Switches D1 and D4, if only one D-T interconnection is on the line segment, sectionalizing could be done with remote circuit breakers, but ATC still recommends switches with load break capability in case other D-T interconnections are added at a later date.

# Appendix F – Interconnection Configurations (Continued)

## Configuration G

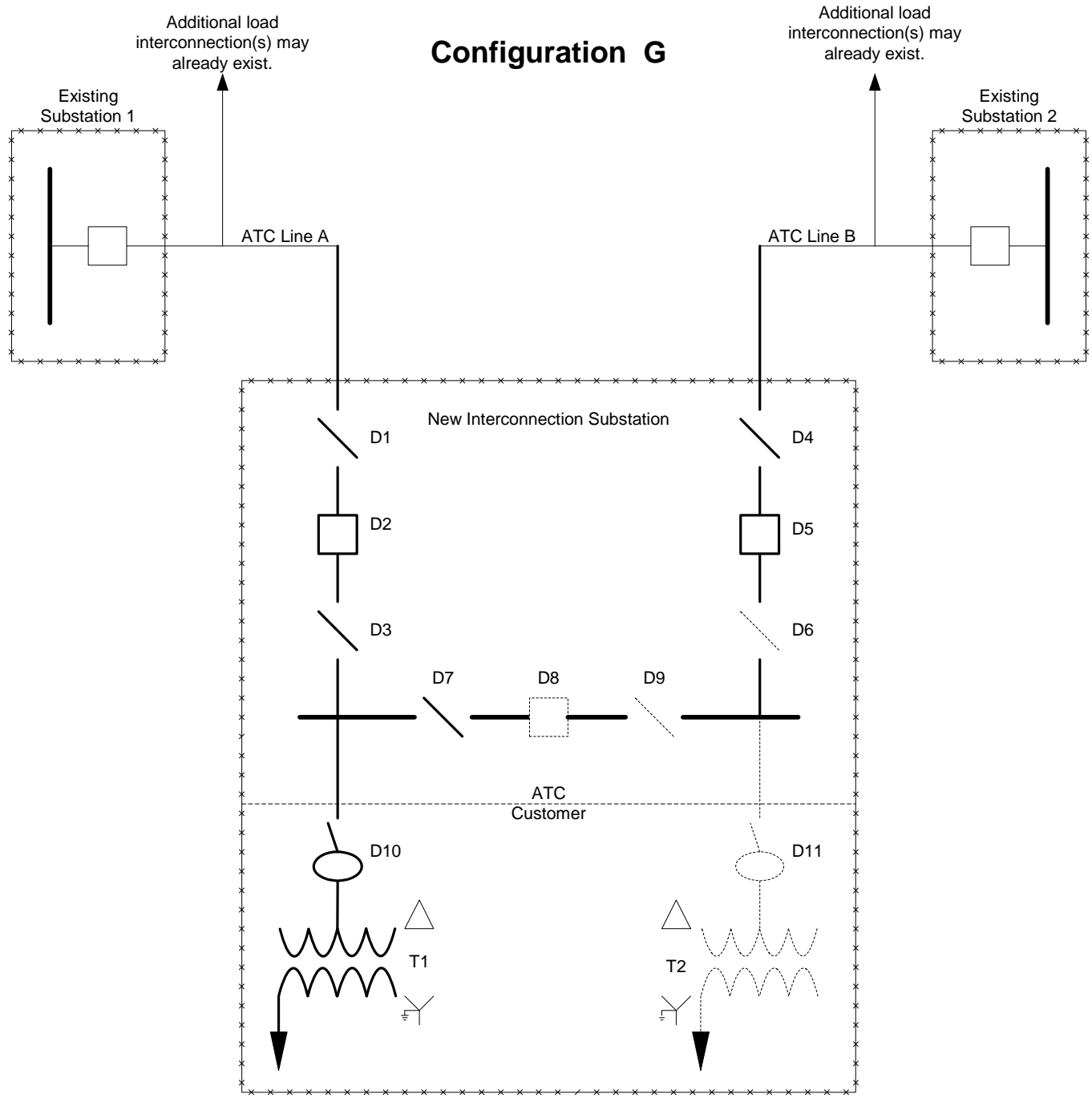
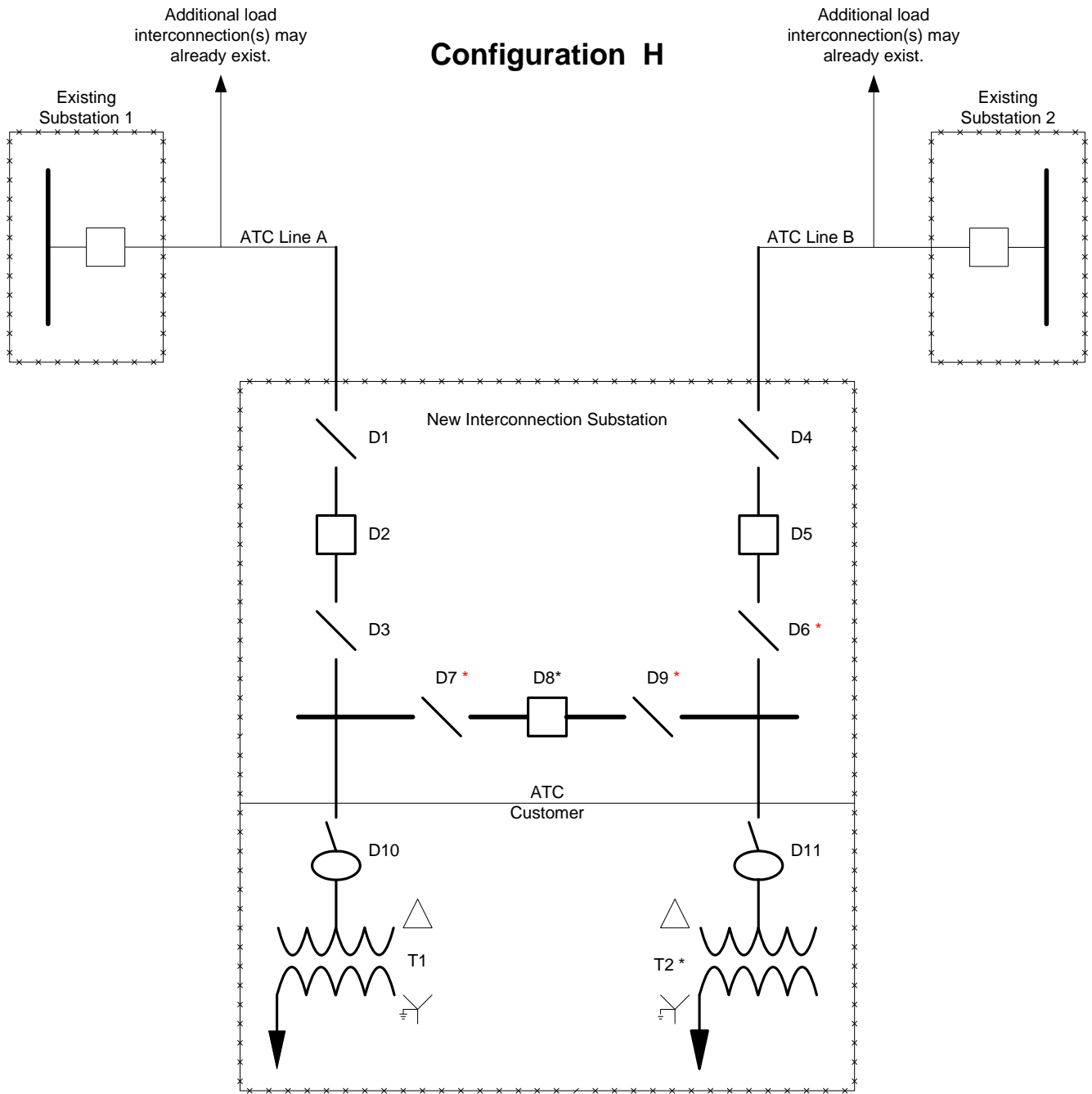

Figure F.8: Load Interconnection Configuration G

Note: For Switches D7 and D9, two switches are to be installed between transformers unless the customer can demonstrate load bridging capability in order to maintain a single switch with both transformers out of service.

# Appendix F – Interconnection Configurations (Continued)



\* If multiple transformers are part of the ultimate design, but if only one will be installed initially, the bus-tie breaker (D8) may be installed at the time an additional transformer is installed. Both maintenance switches (D7 and D9) associated with the bus-tie breaker as well as switch D6 will be installed as part of the initial design.

Figure F.9: Load Interconnection Configuration H

# Appendix F – Interconnection Configurations (Continued)

## Configuration J

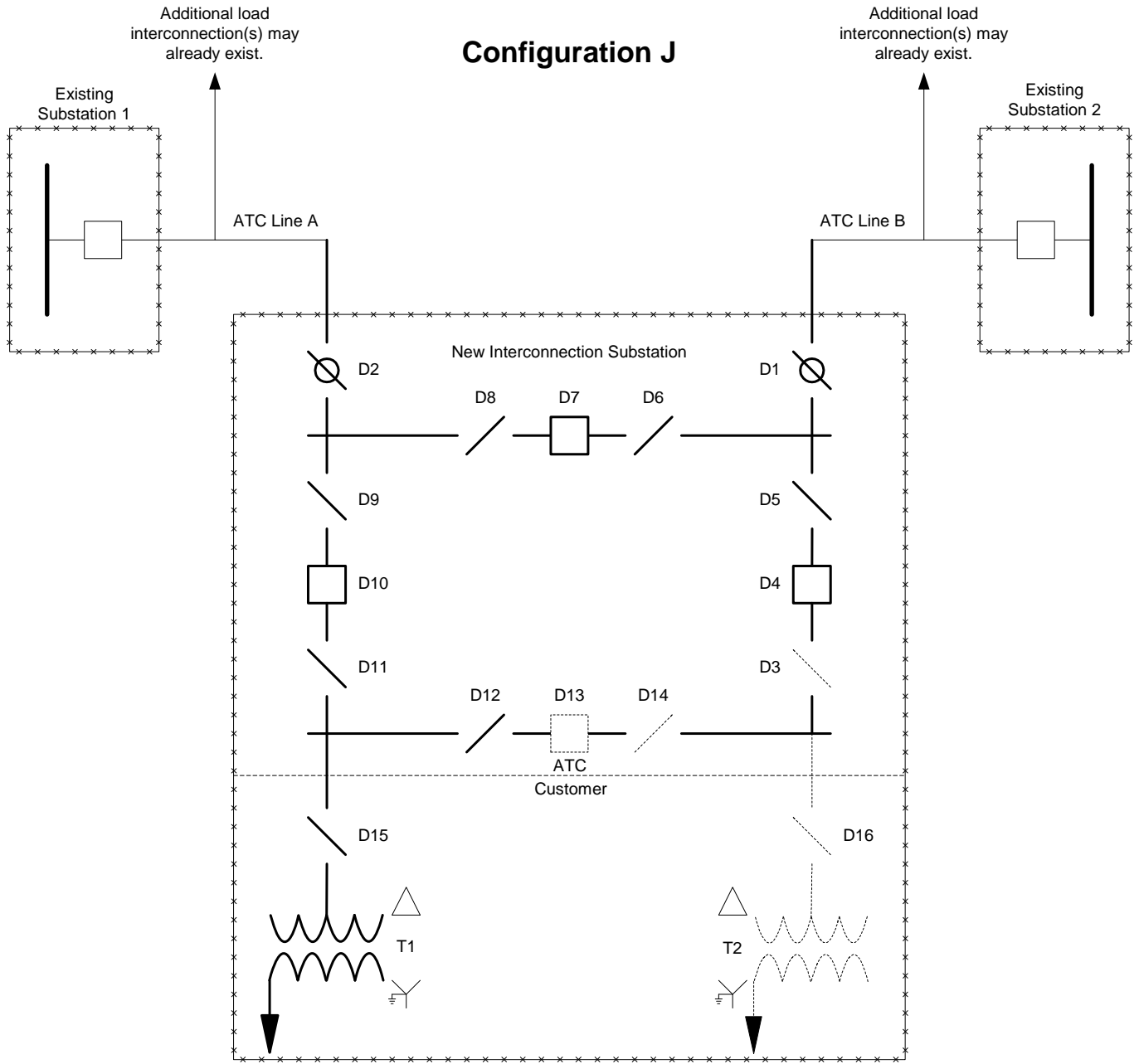
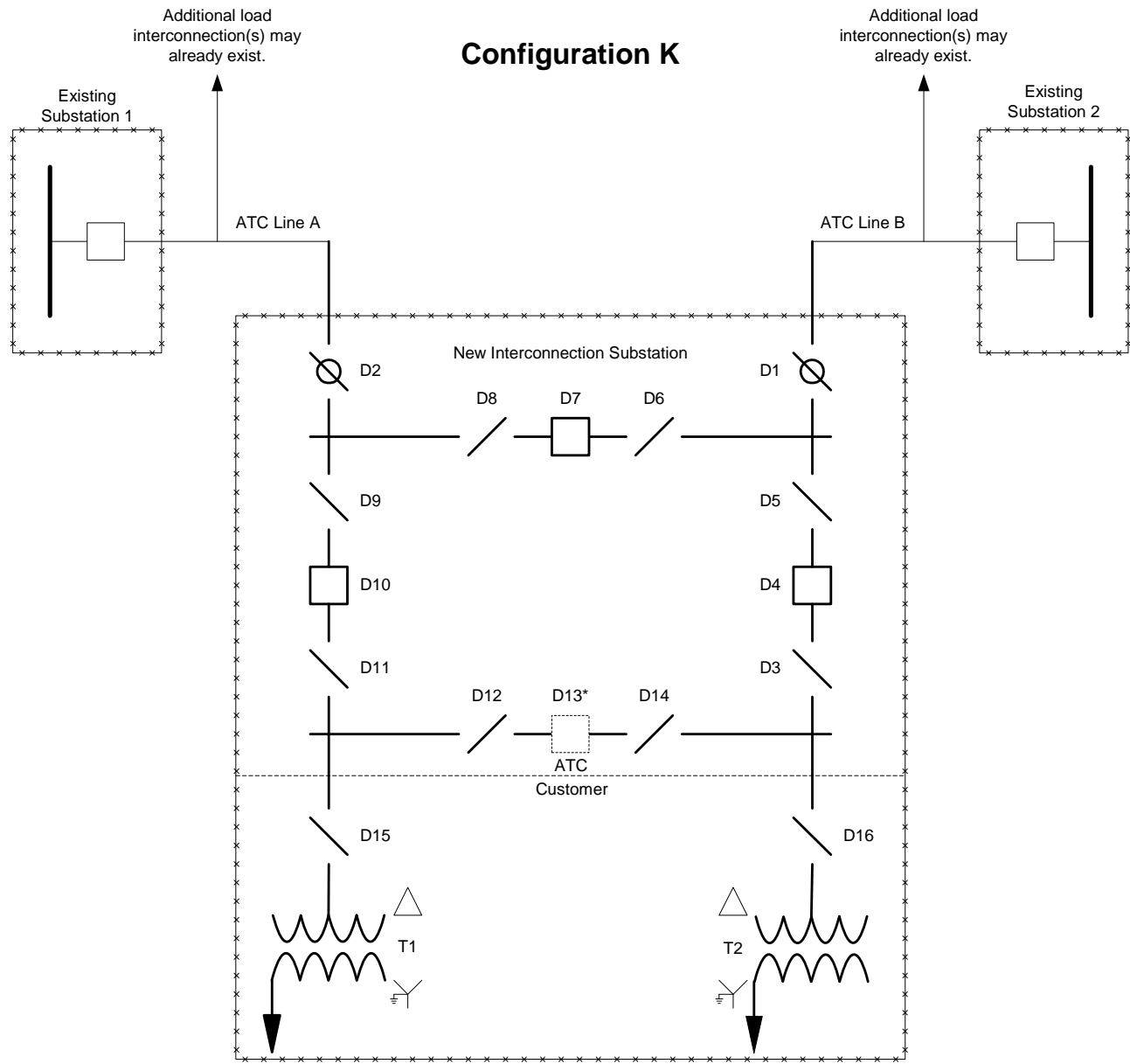

Figure F.10: Load Interconnection Configuration J

# Appendix F – Interconnection Configurations (Continued)



\* If multiple transformers are part of the ultimate design and total load between them is  $\geq 30$  MW, installation of breaker D13 would be standard. However, if only one transformer will be installed presently, breaker D13 may be installed at the time an additional transformer is installed. Both maintenance switches (D12 and D14) will be installed as part of the present design.

Figure F.11: Load Interconnection Configuration K

# Appendix F – Interconnection Configurations (Continued)

## Configuration L

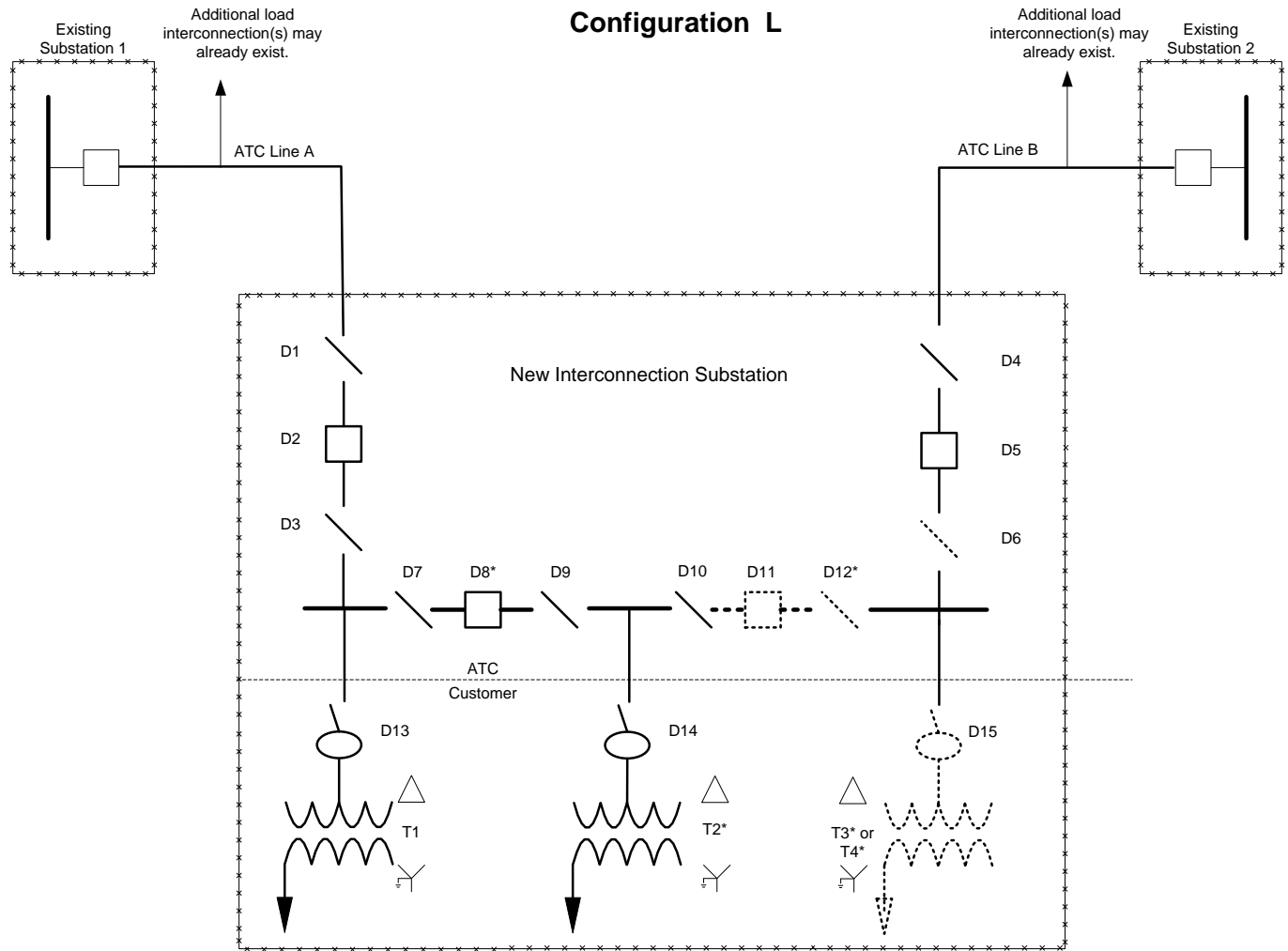

\* If three transformers are part of the ultimate design, but only two will be installed presently, the bus-tie breaker (D11) may be installed at the time a third transformer is installed. Maintenance switch (D10) will be installed as part of the present design.

Figure F.12: Load Interconnection Configuration L