



# Generator Interconnection Guide

AMERICAN TRANSMISSION COMPANY

# Generator Interconnection Guide

---

Revision 1.0  
December 16, 2008

American Transmission Company  
N19 W23993 Ridgeview Pwky. W.  
Waukesha, WI 53188-1000

**A**merican Transmission Company (ATC) is a member of the Midwest Independent Transmission System Operator (Midwest ISO)<sup>1</sup>. ATC owns, plans, constructs, operates, maintains and will expand its transmission facilities to provide adequate and reliable transmission of power. ATC provides nondiscriminatory service to all customers, supporting effective competition in energy markets without favoring any market participant. ATC owns approximately 9,100 miles of transmission lines and 480 substations in portions of Wisconsin, Michigan, Minnesota and Illinois and is interconnected with more than 40 generating facilities owned by municipalities, cooperatives, independent power producers and investor-owned utilities. In general, ATC accommodates additions or modifications for generation customers according to the requirements of the Midwest ISO's Open Access Transmission and Energy Markets Tariff. ATC will collaborate with Midwest ISO and the Customer in development and implementation of the appropriate interconnection solution in response to the Customer's requested need. The Customer is directed to the Midwest ISO for formal submittal of a generator interconnection request for each of the following types of project:

1. Interconnection of new generating capacity to the ATC Transmission System.
2. Modifications<sup>2</sup> to existing interconnected Generating Facilities, as defined by the Midwest ISO.

This Generator Interconnection Guide is intended to supplement the Midwest ISO requirements and address ATC's role in that process.

Any questions or requests for additional information concerning generation interconnections to the ATC Transmission System should be directed to:

[gioanotices@atcllc.com](mailto:gioanotices@atcllc.com)  
ATC Interconnection Services  
**262-506-6700**

---

<sup>1</sup> Capitalized terms are defined in the Glossary at the end of this Guide or the Midwest ISO's Open Access Transmission and Energy Markets Tariff.

<sup>2</sup> It is possible that the Customer may have proposed modifications that the Midwest ISO would not consider as "Material Modifications" according to the MISO tariff, but may otherwise have an impact on the transmission system or generation-transmission interconnection requiring the analysis of ATC as discussed in Section 1.B.

# Table of Contents

|      |                                     |    |
|------|-------------------------------------|----|
| 1    | Introduction                        | 1  |
| 1.1  | Purpose                             | 1  |
| 1.2  | ATC's Role                          | 1  |
| 1.3  | Legal and Regulatory Requirements   | 2  |
| 2    | Process                             | 2  |
| 2.1  | Initiation and Development          | 2  |
| 2.2  | Interconnection Studies             | 3  |
| 2.3  | Data Requirements                   | 3  |
| 2.4  | Interconnection Agreement           | 4  |
| 3    | Design Requirements                 | 4  |
| 3.1  | Interconnection Configuration       | 5  |
| 3.2  | Demarcation and Ownership           | 7  |
| 3.3  | Substation Site                     | 7  |
| 3.4  | Power Factor                        | 8  |
| 3.5  | Reactive Capability                 | 8  |
| 3.6  | Low Voltage Ride-Through Capability | 8  |
| 3.7  | Generation Reactive Control         | 8  |
| 3.8  | Voltage Flicker and Harmonics       | 9  |
| 3.9  | Frequency                           | 9  |
| 3.10 | Fault Current                       | 9  |
| 3.11 | Power Quality                       | 9  |
| 3.12 | Auxiliary Power                     | 9  |
| 4    | Protection                          | 9  |
| 4.1  | General                             | 9  |
| 4.2  | Utility Grade Relays                | 10 |

|      |   |    |
|------|---|----|
| 4.3  | Frequency Protection (IEEE 81)                                  | 11 |
| 4.4  | Customer Breaker Failure Protection (IEEE 50BF)                 | 11 |
| 4.5  | Synchronism Check Relay (IEEE 25)                               | 11 |
| 4.6  | Bus Differential Protection (IEEE 87)                           | 11 |
| 4.7  | Reverse Power (IEEE 32)   | 12 |
| 4.8  | Power Transformer Ground Time Overcurrent Protection (IEEE 51N) | 12 |
| 4.9  | Protection Redundancy   | 12 |
| 4.10 | Generator Tripping  | 12 |
| 4.11 | Recommended Generator Protection Functions                      | 12 |
| 4.12 | Transmission Line Automatic Reclosing Near Generating Facility  | 13 |
| 4.13 | Grounding   | 14 |
| 4.14 | Equipment Ratings   | 14 |
| 5    | Telemetry and Metering Requirements                             | 14 |
| 5.1  | Telemetry   | 14 |
| 5.2  | Balancing Authority Metering                                    | 16 |
| 6    | Testing, Inspection and Commissioning                           | 16 |
| 6.1  | Testing and Inspection  | 16 |
| 6.2  | Energization Requirements                                       | 16 |
| 6.3  | Reduction of DC Residual Flux                                   | 16 |
| 6.4  | Synchronizing Requirements                                      | 17 |
| 7    | Requirements after Commercial Operation                         | 17 |
| 7.1  | Operating Guidelines  | 17 |
| 7.2  | Generating Facility Voltage Schedule                            | 17 |
| 7.3  | Unit Stability Requirements                                     | 17 |
| 7.4  | System Restoration (Black Start)                                | 18 |
| 7.5  | Maintenance Testing   | 18 |
|      | Appendix A: Glossary of Terms                                   | 19 |

|   |    |
|---|----|
| Appendix B: Generator Data Requirements               | 23 |
| B.1 Generator/Turbine Design Data                     | 23 |
| B.2 Excitation System Design Data                     | 24 |
| B.3 Governor Design Data                              | 24 |
| B.4 Power System Stabilizer Data                      | 25 |
| B.5 Transformer Data                                  | 25 |
| B.6 One-Line Diagram of the Customer's Equipment      | 26 |
| B.7 Generator MW Output Level                         | 26 |
| B.8 Unit Start-Up Requirements                        | 26 |
| B.9 Reactive Compensation System Design               | 26 |
| B.10 Voltage Schedule and Automatic Voltage Regulator | 27 |
| B.11 Low Voltage Ride-Through Capability              | 27 |

# 1 Introduction

## 1.1 Purpose

As a Transmission-only utility, ATC partners with its interconnected and interconnecting Customers for long-term, successful generator interconnections. This Generator Interconnection Guide describes the minimum requirements for the connection of generation to the ATC Transmission System. Additional specific requirements will be identified during studies conducted in connection with the particular Customer-proposed project. The Federal Energy Regulatory Commission (FERC) set forth the process for interconnection of generation to the Transmission System in its Order No. 2003 and, for non-synchronous generation, in its Orders No. 661 and 661-A.<sup>3</sup> This process is administered by the Midwest Independent Transmission System Operator (Midwest ISO) according to the Generator Interconnection Procedures (GIP) of its Open Access Transmission and Energy Markets Tariff (Tariff). The GIP govern the interconnection of new or increased generating capacity to the transmission facilities subject to the Midwest ISO Tariff, including ATC-owned transmission facilities<sup>4</sup>. This Guide generally applies to the interconnection of new generating capacity. New interconnections at existing substations will be designed utilizing this Guide while accommodating previous interconnection requirements and limitations. If the Customer is considering any modification(s) to an existing generator that may be reasonably anticipated to impact the Transmission System or the interconnection, the Customer should notify ATC in writing of the proposed modification(s) and ATC will provide guidance on how to proceed.

This Guide does not apply to generation connected to Distribution Systems that are themselves interconnected to the ATC Transmission System (generally those operating at voltages below 50 kV). For information concerning such distribution-connected generation, reference the *ATC Load Interconnection Business Practice* on the ATC Web site at [http://oasis.midwestiso.org/documents/ATC/Load Interconnection Business Practice.pdf](http://oasis.midwestiso.org/documents/ATC/Load_Interconnection_Business_Practice.pdf) and the *ATC Load Interconnection Design Guide*.

## 1.2 ATC's Role

ATC performs the Interconnection System Impact Study within the System Planning and Analysis Phase and the System Impact Study and Facilities Study within the Definitive Planning Phase at the direction of the Midwest ISO for generator interconnection requests made to the Midwest ISO and related to the ATC Transmission System. For Customer proposed modifications to existing Generating Facilities, ATC will perform analysis to determine any impact on the Transmission System and determine the time and

---

<sup>3</sup> *Standardization of Generation Interconnection Agreements and Procedures*, Order No. 2003 *et seq.*, Fed. Reg. Vol. 68, No. 160 (August 19, 2003), Order 661, 111 FERC ¶ 61,353 (June 2, 2005) and Order 661-A, 113 ¶ 61,254 (December 12, 2005).

<sup>4</sup> For the purpose of this Guide, the term “transmission facilities” means electric lines and related facilities that are operated at 50 kV and above.

costs of those upgrades. The ATC Interconnection Services group coordinates ATC's collaboration with the Customer and the Midwest ISO throughout the interconnection process. ATC also performs unit verification studies prior to commercial operation of the Generating Facility using the as-built information for the plant to ensure that the Generating Facility information as was studied is consistent with the Facility as installed. Additionally, ATC will review the role of any proposed Generating Facility in ATC's Black Start Plan.

### 1.3 Legal and Regulatory Requirements

#### 1.3.1 FERC

Throughout the interconnection process, ATC adheres to the FERC Standards of Conduct<sup>5</sup>.

#### 1.3.2 State

The states in which ATC operates have their own requirements for generator siting and construction. This Guide is not intended to describe those requirements. The Customer will be responsible for compliance with the specific state requirements and processes. Further information regarding these requirements and processes is available from the pertinent state regulatory agency:

- Public Service Commission of Wisconsin - <http://www.psc.wi.gov/>
- Michigan Public Service Commission - <http://www.michigan.gov/mpsc/>
- Minnesota Public Utilities Commission - <http://www.puc.state.mn.us/>
- Illinois Commerce Commission - <http://www.icc.illinois.gov/>

#### 1.3.3 NERC

ATC is registered as a Transmission Owner, Transmission Operator, Transmission Planner, and Planning Coordinator with both the Midwest Reliability Organization and ReliabilityFirst Corporation under the requirements of the electric reliability organization, the North American Electric Reliability Corporation's (NERC).

## 2 Process

The specific steps and requirements of the process for interconnecting new generating capacity to ATC's transmission facilities are set forth in detail in the Midwest ISO Generator Interconnection Procedures (GIP).

### 2.1 Initiation and Development

---

<sup>5</sup> Order No. 888, 61 FR 21540 (May 10, 1996)

A Customer request for interconnection to the Midwest ISO begins the MISO Pre-Queue and Application Review process. The specific requirements of the interconnection request are available on the Midwest ISO website Generator Interconnection page at <http://www.midwestmarket.org/page/Generator%20Interconnection>. In addition to the formal mechanisms, ATC encourages communication throughout the process and offers meeting with prospective generator Customers prior to and during the development of the interconnection request.

## 2.2 Interconnection Studies

The Midwest ISO and ATC will work with the Customer through the study process.

- a. Application Review
- b. System Planning & Analysis (the SPA)
  - Interconnection System Impact Study includes short circuit, stability and power flow analysis to determine the appropriate Network Upgrades and Interconnection Facilities to accommodate the Customer interconnection request.
- c. Definitive Planning
  - Interconnection System Impact Study or Restudy may be required to support transition to Definitive Planning.
  - Interconnection Facilities Study is an engineering report with scope, schedule and cost estimates for design and construction of the Network Upgrades and Interconnection Facilities.

The Customer may consult the Midwest ISO GIP for further details on Milestones and the scope, timeframe and deposits for each of the Interconnection Studies.

## 2.3 Data Requirements

Throughout the studies and interconnected operation of the Generating Facility, certain information is required from the Customer. ATC will assign key lead contacts during the interconnection process from ATC's Interconnection Services and Planning groups to assist Customers in the determination and sharing of the needed information. Generally, the required information fits into the categories noted in Table C.1 below. Further detail is found in Appendix B to this Guide.

**Table 2-1: Midwest ISO Generator Interconnection Process Summary**

| Process                                     | Components  | Required Information   |
|---|---|--|
| <b>Pre-Queue and Application Review</b>     | <ul style="list-style-type: none"> <li>- Pre-Queue Discussions</li> <li>- Application to MISO</li> <li>- Meet Milestone 1 (M1)</li> <li>- Feasibility Study</li> <li>- G-T Study Process Path Decision (SPA or Definitive Planning)</li> </ul>  | Generic stability model; Point of Interconnection (POI); impedance to POI; one-line diagram; generation output; step-up transformer data; proof of site control  |
| <b>System Planning &amp; Analysis (SPA)</b> | <ul style="list-style-type: none"> <li>- System Impact Study</li> </ul>   | Generating Facility unit ratings, exciter data, reactance, time constants and curves; step-up transformer data; governor data; excitation system data; Wind Farm specific data.  |
| <b>Definitive Planning</b>                  | <ul style="list-style-type: none"> <li>- Meet Milestone 2 (M2)</li> <li>- SPA Review and Potential Restudy (if SPA path taken)</li> <li>- Abbreviated System Impact Study (if SPA path not taken)</li> <li>- Meet Milestone 3 (M3)</li> <li>- Facilities Study</li> <li>- IA Negotiation</li> </ul> | M2 - Detailed stability model; definitive POI; definitive one-line diagram; definitive generation output; proof of site control; necessary permits; regulatory approval; board approval; M2 deposit<br>M3 – one of three: (1) Deposit equal estimated cost of Network Upgrades, (2) Power purchase agreement or evidence of inclusion in state resource adequacy plan, or (3) Evidence of turbine order. |
| <b>Construction</b>                         |   | Any required technical data, including: <ul style="list-style-type: none"> <li>- Interconnection substation location and detail</li> <li>- Preliminary and final design</li> </ul>   |

2.4 Interconnection Agreement

After the Interconnection Studies are completed, the Customer, ATC and the Midwest ISO will enter into a Generator Interconnection Agreement (GIA). The GIA sets forth a schedule of milestones for the construction of the Interconnection Facilities and Network Upgrades necessary to interconnect the proposed new generating capacity, as determined by the Interconnection Studies. The schedule reflects the expected time to obtain all necessary governmental and regulatory approvals and permits required for the construction and operation of the Generating Facility and associated Transmission System facilities.

The GIA also establishes the terms and conditions for the interconnected operation of the Facility including, among other things, operational coordination, outage scheduling, planned and emergent maintenance, future modifications, billings and payments.

3 Design Requirements

In addition to applicable design standards identified in the respective GIA, the Customer must comply with the most recent ATC substation/transmission/protection design guides, standards,

and specifications, where applicable, for the design of and procurement for the interconnection of the Generating Facility. The ATC design guides, standards, and specifications are available upon request.

In the event that such ATC design guides, standards or specifications do not address a particular item or issue, the Customer will use nationally-recognized standards, guides or specifications to ensure that the Customer's facilities are designed in accordance with Good Utility Practice and any applicable mandatory reliability standards. In the event that there is a conflict between any mandatory standard, guide or specification and ATC's design guides, standards and material/construction specifications, the more restrictive design guides, standards and specifications will apply.

### 3.1 Interconnection Configuration

#### 3.1.1 Minimum Configuration

The configuration of the interconnection substation will depend on several factors including, but not limited to the number and size of units connected, the number of transmission outlets either existing or required and whether or not any of the transmission lines are part of a black-start restoration path. The configuration of the Interconnection Facilities will be determined through the study process. However, the exact transmission line and substation locations may be modified during the detailed design and regulatory process.

The minimum configuration for the ATC interconnection substation will be a straight-bus with two (2) breakered line terminals ("loop-through"). As shown in Figure 3-1, the Customer will, at minimum, procure, install, own and maintain a circuit breaker and disconnect switch between the ATC Interconnection Facilities and the high side of the Customer's step-up transformer to transmission voltage to be located in the Customer's substation. As shown in Figure 3-2, an ATC-owned circuit breaker and disconnect switch may also be required as part of the ATC Interconnection Facilities in instances where the Customer does not have personnel available to promptly restore the Customer's breaker to service after an unplanned outage and/or operate its disconnect switch on the high-side of the Customer's circuit breaker.

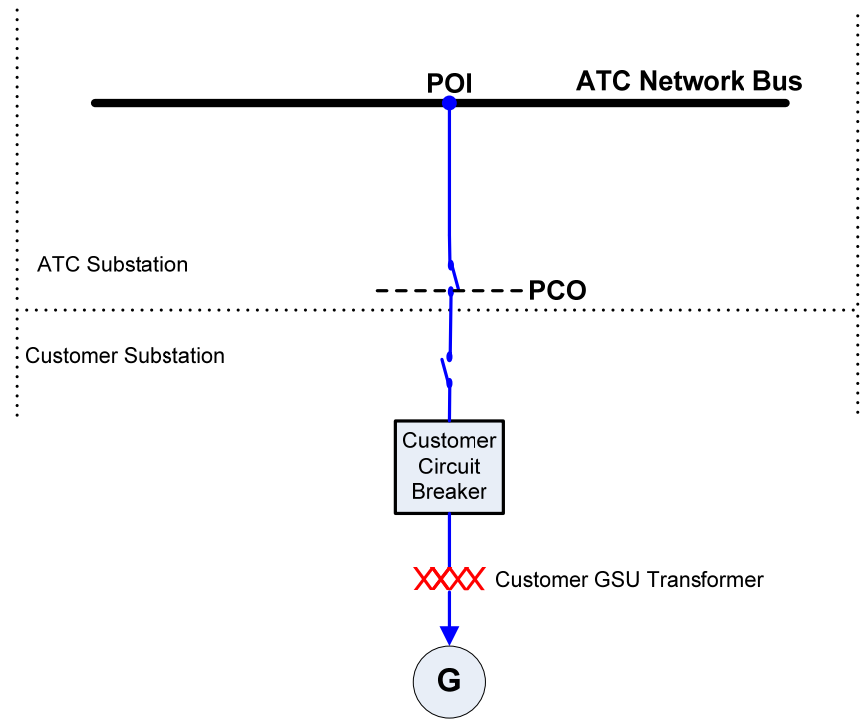

**Figure 3-1: Minimum Configuration**

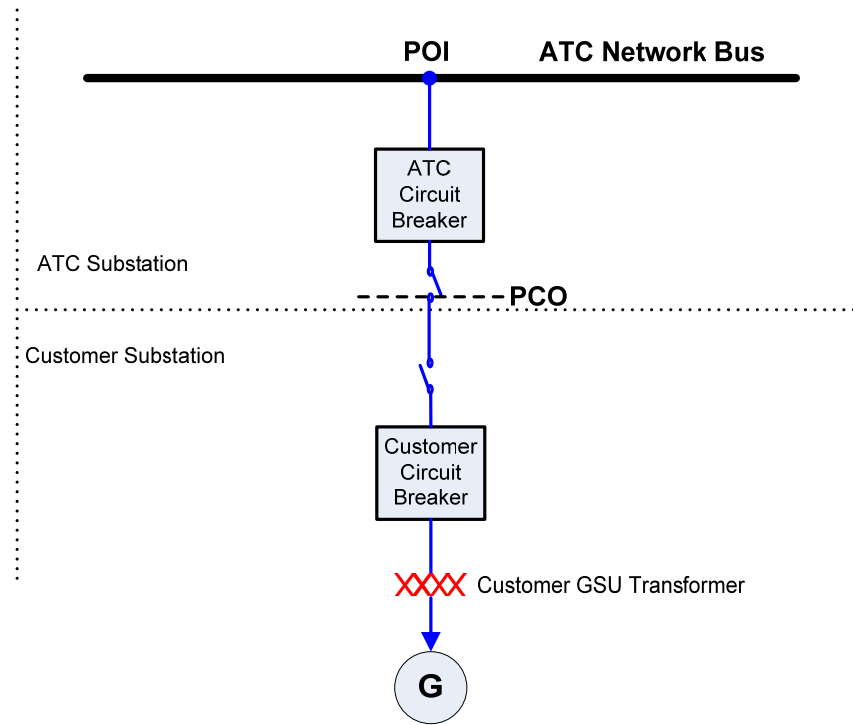

**Figure 3-2: Alternate Configuration**

3.1.2 Proximity of ATC and Customer Substations

For an ATC interconnection substation built adjacent to the Customer’s substation, the connection between the ATC network bus and the Customer’s substation will be considered by ATC as a bus extension and will not typically require a bus-tie breaker. However, if the substations are not adjacent, the connection will be considered a line, not a bus extension, and a line protection scheme will be employed by ATC.

3.2 Demarcation and Ownership

The Point of Interconnection (POI) will be the point at which the ATC Interconnection Facilities connect to the ATC interconnection substation bus. The Point of Change of Ownership (PCO) will be at the point at which the strain bus from the Customer’s substation connects to the dead end structure of the ATC Interconnection Facilities located in the ATC interconnection substation. In the event that the interconnection is via rigid bus conductor, the PCO will be the terminal connection of ATC’s switch in the ATC interconnection substation.

3.3 Substation Site

ATC’s interconnection substation will be designed as an entirely separate substation from the Customer’s substation. The Customer will be required to provide a suitable site for the ATC interconnection substation and Customer will be required to convey to ATC all

necessary easements, in a form acceptable to ATC, over all property owned, leased or otherwise controlled by the Customer, including easements for ingress/egress to permit ATC access to all of the ATC Interconnection Facilities and Network Upgrades, which are on the property of the Customer. Additionally, the Customer must provide a site that is acceptable to ATC, which includes rough grade requirements and is sufficiently large enough to accommodate the present and future uses of ATC. The specific real estate requirements will be determined during the detailed design. If the Customer's substation is adjacent to the ATC interconnection substation, a fence separating them will be required.

#### 3.4 Power Factor

ATC's standard power factor range for synchronous and non-synchronous (e.g., wind turbines) generation is 0.95 leading (when a facility is consuming reactive power from the Transmission System) to 0.90 lagging (when a facility is supplying reactive power to the Transmission System)<sup>6</sup>. The Generating Facility must be capable of maintaining a composite power delivery at the Point of Interconnection across ATC's standard power factor range at all power output levels between 10% and the Facility's maximum rated power output. Continuous dynamic operation by non-synchronous machines throughout the power factor design range as measured at the Point of Interconnection may be required if the Interconnection Studies identify this requirement. Such operation will account for the net effect of all energy production devices on the Customer's side of the PCO.

#### 3.5 Reactive Capability

The Customer will be required to provide to ATC the following Original Equipment Manufacturer data; Original Excitation Limit and Minimum Excitation Limitation for the Generating Facility, including but not limited to all data that describes the electrical characteristics of the generator, step-up transformers and auxiliary transformers, such as generator capability curves demonstrating compliance with ATC's power factor requirements, excitation system description and limits, turbine and generator output capability and any ambient or otherwise seasonal variations together with any protection equipment settings that might restrict steady state or dynamic generator response.

#### 3.6 Low Voltage Ride-Through Capability

All generators connected to the transmission network must be capable of "riding through" disturbances that depress system voltages, as required by FERC Orders 661-A and 693. All generators must communicate the low voltage as-built ride-through capability of the Generating Facility following the Commercial Operation Date. See Appendix B for an example.

#### 3.7 Generation Reactive Control

---

<sup>6</sup> These values have been approved by the FERC for use by ATC. (cf. FERC Orders ER05-1475 and ER06-866)

The Customer must design the Facility such that voltage and reactive power controls are included on each generator to be interconnected along with provision for power system stabilizers, except where exempted by the FERC. Depending on the size and location of the generator, a power system stabilizer may be required for interconnection. The Customer should review all Applicable Reliability Standards.

### 3.8 Voltage Flicker and Harmonics

The energization and operation of any generator equipment must be consistent with ATC's Tariff-required Planning Criteria and Operating Instructions 04-01 and 04-02 regarding permissible voltage deviations, flicker and distortion. ATC's Planning Criteria and Operating Instructions are available upon request.

### 3.9 Frequency

The interconnected Transmission System has a nominal operating frequency of 60 Hz. In accordance with Applicable Reliability Standards, the Customer will install both generation controls and protective relaying equipment necessary to maintain proper Transmission System frequency (cf. Section 4.3).

### 3.10 Fault Current

Customer facilities connected to ATC's Transmission System can be subjected to fault levels that are largely the product of system characteristics and interconnection impedance. The customer's facilities must possess sufficient fault interrupting and momentary withstand ratings to meet the maximum expected fault current, with appropriate margin for future system growth. ATC will provide the transmission contribution to the fault current levels at the Point of Interconnection in the System Impact Study reports and otherwise at the request of the customer.

### 3.11 Power Quality

All Customer and ATC facilities will be designed to eliminate excessive voltage flicker and to avoid the introduction of excessive distortion to the sinusoidal voltage or current waves as defined by ATC Operating Instruction 04-01 and 04-02, which are available upon request.

### 3.12 Auxiliary Power

The Customer shall procure its own primary and secondary sources of auxiliary power for its substation. ATC shall procure its own primary source of auxiliary power for the ATC Interconnection Substation. ATC may require the Customer to provide, at Customer's expense, a secondary source of auxiliary power to the ATC Interconnection Substation off of the Customer's substation equipment.

## 4 Protection

### 4.1 General

All generator interconnections to the ATC Transmission System shall be designed to avoid safety hazards or to avoid adversely affecting the quality of electric transmission service to ATC customers. Protective equipment may need to be added to standard ATC facilities to provide adequate protection of the Transmission System. Requirements for additional protective equipment due to additional generation will vary depending upon the size of the generator and on the nature of ATC's local system.

#### 4.1.1

As part of the protection facilities, ATC will construct a protective relaying scheme to protect the Transmission System from faults occurring on the Customer's Interconnection Facilities or the Generating Facility, and from faults occurring on the ATC Interconnection Facilities and Transmission System. The Customer will be responsible for protecting the Generating Facility and all Customer Interconnection Facilities from faults occurring on its facilities, and from faults occurring on the ATC Transmission System.

#### 4.1.2

The Customer will design, install, set, and maintain all protective devices necessary to protect the Generating Facility in accordance with ANSI/IEEE standards, Good Utility Practice(s), Applicable Reliability Standards, the Interconnection System Impact and Facilities Studies and applicable standards and guides. Protective devices, including those performing the protective functions required by ATC in accordance with this Guide, will be installed by the Customer to disconnect the Generating Facility from the ATC Transmission System whenever a fault, abnormal operating condition or equipment failure occurs. The Customer will ensure that such protective devices and related equipment properly coordinate with ATC protective equipment, both locally and remotely, and provide a comparable level of protection to the Generating Facility and the Customer Interconnection Facilities as is provided by ATC for the ATC Interconnection Facilities and Transmission System. The specific requirements and specific protective devices to be installed will be determined in the Interconnection Studies.

#### 4.1.3

The Customer shall allow ATC to review the Generating Facility protection, control design and settings, and their coordination, where applicable, with the ATC protective devices prior to and after the Commercial Operation Date. ATC reserves the right to refuse to allow the Customer to initiate the tender of energy to the ATC Transmission System if, in the judgment of ATC, the Facility protection devices, controls or overall protection methods do not adequately prevent the Generating Facility from introducing or causing a fault related adverse impact on the ATC Transmission System.

### 4.2 Utility Grade Relays

Protective and control relays utilized by the Customer shall:

- a. Meet or exceed ANSI/IEEE standards for protective relays (i.e., C37.90-1989, C37.90.1-1989, and C37.90.2-1995).
- b. Have the appropriate documentation covering application, testing, maintenance, and service.
- c. Give positive indication of what has caused a trip (targets).
- d. Have a means of testing that does not require disturbance to wiring (e.g. a draw-out case, test-blocks, test switches, etc.).

The Customer shall use microprocessor-based protective relays that include self-diagnostic abilities, sequence of events, event-recording capabilities, and operating flexibility.

4.3 Frequency Protection (IEEE 81)

The design of the generating facility relating to over-frequency protection of the Generating Facility is discretionary with the Customer; however, the over-frequency protection used by the Customer will be communicated to ATC. Under-frequency protection will be in accordance with the Applicable Reliability Standards.

4.4 Customer Breaker Failure Protection (IEEE 50BF)

The Customer shall install a local dedicated 50BF breaker failure protective relay on its breaker on the high-side of the generator step-up transformer. The 50BF relay will be coordinated with ATC in order to trip adjacent substation breakers, in the event the generator breaker fails to successfully open for any reason.

4.5 Synchronism Check Relay (IEEE 25)

The Customer will synchronize the Generating Facility to the Transmission System across the Customer-owned breaker installed on the high-side of the generator step-up transformer. The Customer shall provide a synchronism-check relay to supervise the automatic or manual synchronization of the Generating Facility to the ATC Transmission System. Automatic synchronism-check relays will contain the manufacturer’s optional voltage monitoring functions and supervise the closing of the circuit breaker. ATC shall be entitled to review the settings and operation of the generator’s synchronism check relay.

4.6 Bus Differential Protection (IEEE 87)

The Customer shall provide a dedicated current transformer input to ATC bus differential protection scheme to provide coordinated bus differential protection of ATC’s bus. This current transformer shall be placed in a manner to ensure that the bus differential protection overlaps the generator bus or step-up transformer protection.

4.7 Reverse Power (IEEE 32)

The protection system for all combustion turbine generators connected to the ATC Transmission System and the reverse power relay pickup shall be set no more than -7% of the machine rated MVA to protect the Transmission System from a possible voltage collapse due to the gas turbine high power consumption during motoring.

4.8 Power Transformer Ground Time Overcurrent Protection (IEEE 51N)

The Customer shall install ground time overcurrent protection for all generator step-up and auxiliary power transformers to protect them from internal ground faults. Such protection will be coordinated with the backup ground time overcurrent protection.

4.9 Protection Redundancy

In accordance with Good Utility Practice, the Customer shall design protection schemes such that no single component failure will prevent the isolation of faults and/or failed equipment. This may require providing redundant or backup protective schemes with separate sensing sources, separate trip paths, dual trip coils on breakers, separate control power supplies, etc.

4.10 Generator Tripping

Each generating unit of the Generating Facility must be capable of disconnecting from ATC's Transmission System in the event of a system fault, abnormal operating condition or equipment or system failure.

4.11 Recommended Generator Protection Functions

ATC recommends the following protective functions, which may provide the Generating Facility with additional backup protection from transmission relaying malfunctions, misoperations, equipment or system failure.

4.11.1 Phase Distance (Impedance) Protection (IEEE 21)

The Customer's distance relay zone that extends into the Transmission System should be time-coordinated with line protective relays to assure transmission protection operates first. The time delay will be set higher than a second zone clearing time for a line fault (typically 20 cycles). Impedance protection is provided for a generating unit when transmission line(s) that connect it to the Transmission System are protected with phase distance relays.

4.11.2 Time Overcurrent with Voltage Control/Restraint (IEEE 51V)

The Customer's overcurrent relays that are voltage-controlled or voltage-restrained should be set below load current for adequate sensitivity to system faults while restraining operation under emergency overload conditions. To prevent miscoordination with transmission relaying, overcurrent relays should be sufficiently time-delayed. The time-delay setting should be based on the worst-

case coordination with ATC protective relays, which is usually a delayed trip with breaker failure clearing times. Backup time overcurrent protection is provided for a Generating Facility when transmission line(s) that connect it to the transmission grid are protected by overcurrent relays.

4.11.3 Backup Ground Time Overcurrent Protection (IEEE 51N)

It is recommended that any backup ground time overcurrent protection operate for ground faults at the end of all transmission lines coming out of the Generating Facility and be set to coordinate with the slowest ground fault protection on the Transmission System. This relay is typically installed in the high-side neutral of the generator step-up transformer.

4.11.4 Negative Sequence Current (Unbalanced Load) Protection (IEEE 46)

The Customer should apply a negative sequence time overcurrent relay to protect the Generating Facility from external unbalanced conditions such as system phase-to-phase faults and open conductors that can damage a generating unit(s).

4.11.5 Out-of-Step (Loss of Synchronism) Protection (IEEE 78)

The Customer shall ensure that each generating unit is capable of separating from the ATC Transmission System before an “out-of-step condition” or loss of synchronism can occur.

4.11.6 Voltage Balance (IEEE 60)

The Customer should ensure the following voltage-dependent protective functions are blocked when a loss of fuse is detected to prevent relaying misoperation:

- a. Phase distance (impedance) protection (IEEE 21);
- b. Under-voltage protection (IEEE 27);
- c. Loss of field (under-excitation) protection (IEEE 40);
- d. Time overcurrent with voltage control/restraint (IEEE 51V);
- e. Under-frequency protection (IEEE 81).

4.12 Transmission Line Automatic Reclosing Near Generating Facility

The automatic re-closing of breakers on ATC transmission lines can be potentially damaging to Customer equipment that is in close electrical proximity to the lines. As a general policy, ATC will not eliminate automatic reclosing of overhead transmission lines near a Generating Facility because that could significantly affect the reliability of service to transmission customers. In order to mitigate possible negative effects of line automatic

reclosing on generating facilities, ATC typically will not reclose lines for the most severe three-phase faults on the Transmission System and will reclose a line first at a terminal remote from the Generating Facility bus, followed by synchronism check reclosing of the breaker at the Generating Facility bus. Automatic reclosing is single-shot and is blocked should a fault be of a permanent nature. ATC may install additional equipment to minimize the potentially adverse effects of automatic reclosing. This usually consists of communication and/or control equipment to disconnect the Generating Facility (or to confirm that it is disconnected) before an ATC line is reclosed.

#### 4.13 Grounding

The Customer must design, install, and maintain grounding facilities to ground the Customer's Interconnection Facilities. ATC reserves the right to approve the grounding system design to insure that the grounding system properly protects ATC's Interconnection Facilities. Additionally, ATC will determine the required short circuit ratings for all of the ATC Interconnection Facilities and Network Upgrades during the detailed design of such items. The Customer shall provide appropriately sized or short circuit-rated Interconnection Facilities comparable to those required by ATC.

The Customer and ATC will design their respective substations' ground grids separately for the maximum available fault current as specified by ATC. The ground grids of both substations will then be connected together at several locations along the common fence before the stations are placed in-service. The Customer and ATC's designs shall address safe touch and step potential not only for their respective ground grids, but also for along the fence line with the connection of the ground grids.

#### 4.14 Equipment Ratings

ATC shall determine the individual equipment ratings for the ATC Interconnection Facilities and Network Upgrades during the detailed design of the facilities in accordance with its design standards and the Interconnection Studies. The Customer shall size its Interconnection Facilities to appropriately coordinate with the ATC Interconnection Facilities.

## 5 Telemetry and Metering Requirements

### 5.1 Telemetry

The Customer shall provide the Transmission Owner with real-time analog and digital facility data. The method in which the signals shall be transmitted to the Transmission Owner's location will be specified during the detail design of the Interconnection Facilities and Network Upgrades. The Customer shall provide the data to the Transmission Owner in an acceptable format. If the Customer can not supply the data in an acceptable format like ICCP, then the Transmission Owner will install an RTU at the Generating Facility to collect this information. Additionally, the Customer shall install and maintain interconnection metering and status data for the connection of each generating unit, except as noted below.

In general, Transmission Owner requires continuous telemetry of the following:

5.1.1 Status of Circuit Breakers

- 5.1.1.1 Capable of disconnecting the Generating Facility from the Transmission Owner's Transmission System.
- 5.1.1.2 Capable of disconnecting any auxiliary load from the Transmission Owners Transmission System.
- 5.1.1.3 Capable of disconnecting any device that is required to be in service to meet the unit(s) requirements for var compensation as part of the interconnection agreement.

5.1.2 Status of Relay Equipment

Status of relay equipment is required when the Customer's relay equipment is protecting, as primary or backup, any of Transmission Owner's Transmission System equipment.

5.1.3 Instantaneous MW and MVAR

For each generating unit at the generator terminal or compensated to the generator terminal. For wind farms, aggregated MW and MVar values at the collection substation.

- 5.1.3.1 For all auxiliary loads connected between the generator terminal and the Point of Interconnection with the Transmission Owner's Transmission System.
- 5.1.3.2 For all auxiliary loads connected to the Transmission Owner's Transmission System.
- 5.1.3.3 For all third-party loads supplied from the Customer's system.

5.1.4 Instantaneous Bus Voltages

- 5.1.4.1 At the terminal of each generator. For wind farms, at the collection substation bus.
- 5.1.4.2 At any device installed pursuant to this GIA to provide static or dynamic var compensation.

5.1.5 In-service and Readiness of:

- 5.1.5.1 Any power system stabilizer installed pursuant to this GIA.
- 5.1.5.2 Automatic voltage regulator (AVR).

5.1.5.3 Any special protection system (SPS) installed pursuant to this GIA.

5.1.5.4 Any reactive compensation, whether static or dynamic, installed pursuant to this GIA.

## 5.2 Balancing Authority Metering

The Customer is responsible for working with an appropriate Balancing Authority to install necessary metering facilities, including instrument transformers within the Customer's substation. Prior to energizing the interconnection via the Transmission System, the Customer must provide evidence of a Balancing Authority Agreement to ATC (see ATC's *Coordination of Balancing Authority Metering Boundary Modifications Business Practice*:

[http://oasis.midwestiso.org/documents/ATC/Coordination\\_Balancing\\_Authority\\_Metering\\_Boundary\\_Modifications.pdf](http://oasis.midwestiso.org/documents/ATC/Coordination_Balancing_Authority_Metering_Boundary_Modifications.pdf).)

# 6 Testing, Inspection and Commissioning

## 6.1 Testing and Inspection

Before final approval for the interconnection is given, the Customer must demonstrate to the Midwest ISO and ATC, through witnessed tests and/or certified test documentation, that the Generating Facility, and each generating unit, will not have adverse impact on the operation of the Transmission System. Such tests and inspections will include pre-energization testing of equipment connected to the transmission bus, protection and control systems and pre-commercial testing of the governor, excitation and/or power system stabilizer controls. Protection and control systems include, but are not limited to, AC auxiliary, DC systems, relaying systems, potential and current circuits, and communication systems.

## 6.2 Energization Requirements

A generator step-up transformer (i.e. the transformer stepping up to transmission voltage) will require the initial energization to occur from the transmission grid. Prior to initial energization, the Customer must permanently install mitigation equipment (e.g., pre-insertion resistors on the high-side transformer circuit breaker) or commission a technical study of the initial energization event to ensure that the initial energization of the transformer will not result in any unacceptable impact to ATC or interconnected customers.

## 6.3 Reduction of DC Residual Flux

The Customer shall perform an excitation current test to determine if the core of the transformer is magnetized. If the test establishes that the core is magnetized, the Customer shall perform the transformer manufacturer recommended procedures to reduce the residual DC flux on the core. The Customer shall then re-perform the

excitation current test to establish the core has been de-magnetized. The Customer shall provide documented results of these procedures to ATC prior to energization.

#### 6.4 Synchronizing Requirements

Unless otherwise permitted by Transmission Owner, the Generating Facility shall be synchronized to the Transmission System at the Customer's high-side circuit breaker installed at the Point of Interconnection. Transmission Owner shall furnish Transmission System bus potentials that may be used by the Customer for synchronizing the Generating Facility to the Transmission Owner's Transmission System.

## 7 Requirements after Commercial Operation

### 7.1 Operating Guidelines

The Interconnection Agreement governs the ongoing operation of the interconnected Generating Facility and Transmission System. In addition, the specific requirements of each interconnection will dictate the establishment of mutually agreeable interconnection and/or operating guidelines that further define the requirements of the interconnection agreement in effect for the Generating Facility.

### 7.2 Generating Facility Voltage Schedule

NERC Mandatory Reliability Standards VAR-001 and VAR-002 set forth the requirements Transmission Operators and Generator Operators/Owners must follow to maintain network voltage schedules. VAR-001 requires that the Transmission Operator specify a voltage schedule at the Point of Interconnection "and direct the Generator Operator to comply with the schedule in automatic voltage control mode (AVR in service and controlling voltage)." VAR-002 requires that the Generator Operator maintain the voltage schedule set by the Transmission Operator and operate each generator in automatic voltage control mode, among other requirements.

VAR-001 provides that "[t]he voltage schedule is a voltage target that must be maintained within a tolerance band during a specified period." Transmission Owner's standard voltage schedule is a target voltage of 102% of the nominal voltage at the Point of Interconnection within a maximum permissible range of 95% to 105% until the Transmission Operator specifies a new voltage schedule. The Generating Facility must be designed and operated for this voltage schedule unless directed otherwise. In addition, operation within a desired tolerance band of 100% to 105% is recommended to ensure efficient and reliable operation of the bulk electric system due to real time system conditions that may not have been specifically modeled in the planning horizon.

### 7.3 Unit Stability Requirements

The Customer shall operate the Generating Facility in accordance with the operating requirements of the Transmission System, the rules of NERC, any applicable regional entity requirements and Transmission Provider in addition to the stability requirements

identified in the Interconnection System Impact Study report, or its equivalent, prepared for this interconnection and which have been posted on the Transmission Provider’s OASIS at:

<http://oasis.midwestiso.org/OASIS/ATC/>

7.4 System Restoration (Black Start)

The Customer is not required to operate as a Black Start Unit unless designated by a separate Black Start Service agreement. However, in accordance with Good Utility Practice, Customer will participate, when called upon by the Midwest ISO or ATC, in ATC’s Black Start Plan for the Generating Facility and ATC’s Transmission System, as well as any verification testing. The Customer is required to supply to ATC its facility black out plans. These plans shall include the equivalized impedance of the systems within the plant auxiliary system to large motors expected to be started during emergency conditions along with the appropriate time-domain modeling assumptions for each large motor to be used by ATC to confirm ATC’s Black Start Plan. ATC will use this information to study the ability of a degraded system to start large motors, such as fans, pumps, and other equipment during system black outs and restoration. The Customer will also be expected to participate in any Black Start Plan verification testing.

7.5 Maintenance Testing

After commissioning of generating equipment, periodic maintenance testing, modification or troubleshooting of Customer equipment shall be done with consideration of the impact to the transmission network and related transmission facilities. Protective relay testing that can trip any element of the transmission network shall be discussed and approved by the ATC System Operator 10 business days prior to testing of equipment.

|                            |                                 |                      |
|----------------------------|---------------------------------|----------------------|
| Effective Date: 12/16/2008 |                                 | <b>Revision: 1</b>   |
| <b>TITLE:</b>              | Generator Interconnection Guide | <b>Page 18 of 18</b> |
|                            | Approved by: <i>Tom Finnes</i>  |                      |

## Appendix A: Glossary of Terms

*Any capitalized terms not defined herein will have the meanings set forth in the Midwest ISO Tariff.*

**Applicable Regional Reliability Organization:** the reliability organization of NERC applicable to the Balancing Authority of the Transmission System to which the Generating Facility is directly interconnected. ATC is a registered member of both Midwest Reliability Organization and ReliabilityFirst Corporation.

**Applicable Reliability Standards:** the requirements and guidelines of NERC, the Applicable Regional Reliability Organization, and the Balancing Authority of the Transmission System to which the Generating Facility is directly interconnected.

**ATC Interconnection Facilities:** all facilities and equipment owned by ATC from the Point of Change of Ownership to the Point of Interconnection as identified in the LGIA or SGIA. The ATC Interconnection Facilities are sole-use facilities and do not include Generator Interconnection Facilities or Network Upgrades.

**Balancing Authority:** an entity responsible for managing an electric system area (a Balancing Authority Area) bounded by interconnection metering and telemetry; and capable of controlling generation to maintain its interchange schedule with other Balancing Authority Areas and contributing to frequency regulation and which has received certification by NERC or a Regional Reliability Council of NERC.

**Commercial Operation:** the status of a Generating Facility that has commenced generating electricity for sale, excluding electricity generated during Trial Operation.

**Customer:** any entity that proposes to interconnect a Generating Facility with ATC's Transmission System.

**Customer's Interconnection Facilities:** all facilities and equipment, as identified in the LGIA, that are located between the Generating Facility and the Point of Change of Ownership, including any modification, addition, or upgrades to such facilities and equipment necessary to physically and electrically interconnect the Generating Facility to the Transmission System or Distribution System, as applicable.

**Electric Reliability Organization:** the North American Electric Reliability Corporation authorized by the Federal Energy Regulatory Commission to promulgate, seek approval for, and enforce Mandatory Reliability Standards.

**Emergency Condition:** a condition or situation: (1) that in the reasonable judgment of the Party making the claim is imminently likely to endanger, or is contributing to the endangerment of, life, property, or public health and safety; or (2) that, in the case of either Midwest ISO or ATC, is imminently likely (as determined in a non-discriminatory manner) to cause a material adverse effect on the security of, or damage to the Transmission System, the ATC Interconnection

Facilities or the electric systems of others to which the Transmission System is directly connected; or (3) that, in the case of the Customer, is imminently likely (as determined in a non-discriminatory manner) to cause a material adverse effect on the security of, or damage to, the Generating Facility or the Customer's Interconnection Facilities. System restoration and black-start will be considered Emergency Conditions; provided that the Customer is not obligated by this LGIA to possess black-start capability. Any condition or situation that results from lack of sufficient generating capacity to meet load requirements or that results solely from economic conditions will not constitute an Emergency Condition, unless one of the enumerated conditions or situations identified in this definition also exists.

**Federal Power Act:** the Federal Power Act, as amended, 16 U.S.C. §§ 791a *et seq.*

**FERC:** the Federal Energy Regulatory Commission or its successor.

**Generating Facility:** the Customer's device(s) for the production of electricity consisting of one or more generating units identified in the Interconnection Request, but not including the Customer's Interconnection Facilities.

**Generating Facility Capacity:** the aggregate net capacity of the Generating Facility where it includes multiple generating units at the Point of Interconnection.

**Generator Upgrades:** the additions, modifications, and upgrades to the electric system of an existing generating facility or of a higher queued Generating Facility at or beyond the Point of Interconnection to facilitate interconnection of the Generating Facility and render the transmission service necessary to affect the Customer's wholesale sale of electricity in interstate commerce.

**Good Utility Practice:** any of the practices, methods and acts engaged in or approved by a significant portion of the electric industry during the relevant time period, or any of the practices, methods and acts which, in the exercise of reasonable judgment in light of the facts known at the time the decision was made, could have been expected to accomplish the desired result at a reasonable cost consistent with good business practices, reliability, safety and expedition. Good Utility Practice is not intended to be limited to the optimum practice, method, or act to the exclusion of all others, but rather to be acceptable practices, methods, or acts generally accepted in the region.

**Governmental Authority:** any federal, state, local or other governmental regulatory or administrative agency, court, commission, department, board, or other governmental subdivision, legislature, rulemaking board, tribunal, or other governmental authority having jurisdiction over the Parties, their respective facilities, or the respective services they provide, and exercising or entitled to exercise any administrative, executive, police, or taxing authority or power; provided, however, that such term does not include the Customer, Midwest ISO, ATC, or any Affiliate thereof.

**Initial Synchronization Date:** the date upon which the Generating Facility is initially synchronized and upon which Trial Operation may begin.

**In-Service Date:** the date upon which the Customer reasonably expects it will be ready to begin use of the ATC Interconnection Facilities to obtain backfeed power.

**Interconnection Agreement:** either the Large Generator Interconnection Agreement or Small Generator Interconnection Agreement in effect for the Generating Facility.

**Interconnection Facilities:** all facilities and equipment between the Generating Facility and the Point of Interconnection, including any modification, additions or upgrades that are necessary to physically and electrically interconnect the Generating Facility to the Transmission System. Interconnection Facilities do not include Generator Upgrades or Network Upgrades.

**Interconnection Facilities Study:** a study conducted by the Midwest ISO, or its agent, for the Customer to determine a list of facilities (including the ATC Interconnection Facilities, System Protection Facilities, and if such upgrades have been determined, Network Upgrades, Distribution Upgrades, Generator Upgrades, and upgrades on Affected Systems, as identified in the Interconnection System Impact Study), the cost of those facilities, and the time required to interconnect the Generating Facility with the Transmission System. The scope of the study is defined in Section 8 of the Midwest ISO Generator Interconnection Procedures.

**Interconnection Feasibility Study:** a preliminary evaluation of the system impact of interconnecting the Generating Facility to the Transmission System, the scope of which is described in Section 6 of the Midwest ISO Generator Interconnection Procedures.

**Interconnection Request:** a Customer's request, in the form of Appendix 1 to the Generator Interconnection Procedures, to interconnect a new Generating Facility, or to increase the capacity of, or make a Material Modification to the operating characteristics of, an existing Generating Facility that is interconnected with the Transmission System.

**Interconnection Study:** any of the following studies: the Interconnection Feasibility Study, the Interconnection System Impact Study, and the Interconnection Facilities Study, or the Restudy of any of the above, described in the Generator Interconnection Procedures.

**Interconnection System Impact Study:** an engineering study that evaluates the impact of the proposed interconnection on the safety and reliability of Transmission System and, if applicable, an Affected System. The study will identify and detail the system impacts that would result if the Generating Facility were interconnected without project modifications or system modifications, focusing on the Adverse System Impacts identified in the Interconnection Feasibility Study, or to study potential impacts, including but not limited to those identified in the Scoping Meeting as described in the Generator Interconnection Procedures.

**Generator Interconnection Agreement (GIA):** the form of interconnection agreement, in the form of Appendix 6 to the Midwest ISO Generator Interconnection Procedures.

**Generator Interconnection Procedures (GIP):** the interconnection procedures that are included in the Midwest ISO Tariff and applicable to an Interconnection Request pertaining to a Generating Facility.

**Mandatory Reliability Standards:** those standards promulgated and approved by NERC as the ERO, or any Regional Entity authorized to do so, as ratified and approved by the FERC that are applicable to ATC and the Customer.

**Midwest ISO:** the Midwest Independent Transmission System Operator, Inc. (the “Midwest ISO”), the Regional Transmission Organization that administers the tariff and provides transmission and energy market services over the transmission facilities of its transmission-owning members in interstate commerce.

**NERC:** the North American Electric Reliability Corporation or its successor organization.

**Network Upgrades:** the additions, modifications, and upgrades to the Transmission System required at or beyond the point at which the Interconnection Facilities connect to the Transmission System to accommodate the interconnection of the Generating Facility to the Transmission System.

**Point of Change of Ownership (PCO):** the point, as set forth in Appendix A to the Generator Interconnection Agreement, where the Customer’s Interconnection Facilities connect to the ATC Interconnection Facilities.

**Point of Interconnection (POI):** the point at which the ATC Interconnection Facilities connect to the ATC Interconnection Substation bus.

**Regional Entity:** the entity or entities that have entered into a delegation agreement with NERC and that have responsibility for the audit and investigation of the compliance with Mandatory Reliability Standards.

**Tariff:** the Midwest ISO Tariff through which open access transmission service and Interconnection Service are offered, as filed with the FERC, and as amended or supplemented from time to time, or any successor tariff.

**Transmission Operator:** any entity responsible for the reliability of its “local” transmission system, and that operates or directs the operations of the transmission facilities.

**Transmission System:** the facilities owned by ATC subject to the administration of the Midwest ISO that are used to provide energy market, transmission service or Wholesale Distribution Service under the Tariff.

**Trial Operation:** the period during which the Customer is engaged in on-site test operations and commissioning of the Generating Facility prior to Commercial Operation.

## Appendix B: Generator Data Requirements

### *New Generator Interconnections*

ATC requires the following minimum information from the Customer to properly model any generator connected to the Transmission System. The Customer will submit most of the information below during Interconnection Studies, but some of the information is not available until later in the design of a power plant. In addition, during design and operation, changes in design information may occur when systems are manufactured, finalized or upgraded in the field. If information has changed since the Customer's last communication with ATC regarding any particular plant's characteristic data, the Customer will need to provide updated information so the generating plant can be properly modeled in future ATC studies, including studies ATC performs to demonstrate compliance with NERC Mandatory Reliability Standards.

The Customer will resubmit data outlined below whenever any of the data changes from typical/estimated to approved/final or due to a design modification.

### *Existing Generator Interconnections*

This information is required not only for new generator interconnections but any changes made to existing generators and associated equipment (i.e. exciters, governors, protection systems, main or auxiliary transformers, etc).

#### B.1 Generator/Turbine Design Data

The Customer will provide following information regarding the generator or turbine itself:

- Manufacturer's Data Sheets (e.g. machine time constants, impedances, total inertia in  $WR^2$  [generator, exciter and turbine combined], inertia constant, voltage base, etc.)
- Normal and emergency high and low voltage limitations for the generator
- Machine design: salient pole, round rotor or induction machine
- Generator capability curve, including:
  - Variations for ambient temperature
  - Excitation limiter curves (including over-excitation and under-excitation limits)
- Generator saturation curves
- List of installation protection with settings/time delays, such as:

- Out of step
- Over-frequency (electrical and mechanical turbine trips), highest steady state high frequency operating point
- Under-frequency (electrical and mechanical turbine trips), lowest steady state low frequency operating point
- Voltage and frequency
- Turbine rated ( $P_{\text{rated}}$ ) and maximum ( $P_{\text{max}}$ ) power capability (ideally as a vertical line superimposed on the generator capability curve), including a description of blades (i.e. multi stage, high, intermediate and low pressure, etc), as well as kVA at rated conditions.
- Over-speed
- Reverse power
- Synchronizing, along with a notation on the one-line on which breaker(s) this is located

## B.2 Excitation System Design Data

The Customer will provide following information regarding the excitation system:

- Excitation block diagram
- Excitation system settings/parameters
- Automatic voltage regulator calculation if equipped with line drop compensation to schedule a voltage at the Point of Interconnection.
- Automatic voltage regulator available operating modes (e.g. constant voltage, constant power factor, constant MVAR, etc.).

## B.3 Governor Design Data

The Customer will provide following information regarding the generator governor:

- Governor block diagram
- Governor settings/parameters, including regulation
- Expected MW response for a range of deviations in frequency (0.05 Hz drop, 0.1 Hz drop, .5 Hz drop, 1.0 Hz drop and 1.5 Hz drop)

#### B.4 Power System Stabilizer Data

As applicable, the Customer will provide following information regarding power system stabilizers (PSS):

- Explicit indication of the installation of a Power System Stabilizer (PSS)
- Power system stabilizer block diagram
- Power system stabilizer settings/parameters
- Tuning study
- Whether or not the PSS can be taken out of service or is an integral part of the functioning excitation system.

#### B.5 Transformer Data

Information shall be provided for the following transformers on the Customer's side of the POI:

- Generator step up transformer(s)
- Unit/main and system/reserve auxiliary power transformer(s)
- Substation transformer(s) (primarily applicable to wind farms but would be true of any site where a collector system less than the POI transmission voltage is used)

For each such transformer noted above, the Customer will provide following information:

- Transformer test report (all transformer types listed above)
- Nameplate drawing and data (all transformer types listed above)
- Impedance
- Ratings
- Nameplate voltages
- Available fixed taps
- Proposed or existing no load (fixed) tap setting
- Normal and emergency high and low voltage limitations for all windings

**B.6 One-Line Diagram of the Customer’s Equipment**

The Customer will provide one-line diagrams of the interconnection configuration (breakers, switches, etc.) including system auxiliary power facilities and collector bus systems. These one-lines must include information on synchronization location, alternate paths for serving auxiliary loads, and relevant system protection information.

**B.7 Generator MW Output Level**

The Customer will provide generator gross and net MW output levels by season. Data will be provided as measured gross at the generator terminals and net at the POI. Auxiliary peak loads and running power factor at the POI should also be provided. The data should be supplied for both minimum and nominal generation levels. The following table is an example of what should be completed for each generating unit to be connected. If the power plant is a combined cycle facility, output levels for both “1 on 1” and “2 on 1” operation should be supplied.

**Table B-1: Example of Generator Provided MW Output Levels**

| Ambient Temp (deg F) | Two Operating Points for Each Generator | Generator Gross Output | Auxiliary Load |          | Net Plant Output |
|----------------------|---|------------------------|----------------|----------|------------------|
|                      |   | P (MW)                 | Aux T1         |          | P (MW)           |
|                      |   |                        | P (MW)         | Q (Mvar) |                  |
| 95                   | Nominal                                 | 200.0                  | 15             | 3        | 185.0            |
|                      | Minimum                                 | 100.0                  |                |          | 85.0             |
| 59                   | Nominal                                 | 210.0                  | 14             | 2        | 196.0            |
|                      | Minimum                                 | 110.0                  |                |          | 96.0             |
| 30                   | Nominal                                 | 220.0                  | 13             | 1.5      | 207.0            |
|                      | Minimum                                 | 120.0                  |                |          | 107.0            |
| 0                    | Nominal                                 | 230.0                  | 12             | 1.5      | 218.0            |
|                      | Minimum                                 | 130.0                  |                |          | 118.0            |

The Customer must also specify if all or a portion of auxiliary load is not served from the generator terminals.

**B.8 Unit Start-Up Requirements**

The Customer will provide the following regarding unit start-up:

- The sequence and size of the motors to be started for unit start-up
- The transmission voltage requirement necessary for successful unit start-up

**B.9 Reactive Compensation System Design**

The Customer will identify any additional reactive power compensation installed to meet the requirements of the Interconnection Agreement. The one-line diagrams shall indicate

the connection of this additional reactive power compensation. The Customer shall supply the reactive compensation control scheme, such as block diagrams, logic diagrams, parameters and settings, and the electrical parameters of each reactive compensation device. The design of the Customer's reactive power compensation shall be consistent with the requirements of the Interconnection Agreement (e.g., if a STATCOM is needed).

**B.10 Voltage Schedule and Automatic Voltage Regulator**

The Customer will maintain the voltage set point as communicated by the Transmission Operator (see Section 7.2 of the ATC Generator Interconnection Guide).

Generating units are required to have a functional and in-service automatic voltage regulator unless specifically exempted by the Transmission Operator. If the automatic voltage regulator fails or is out of service, this information must be communicated to the Transmission Operator in accordance with national, interconnection-wide and regional reliability standards and the Interconnection Agreement. Generating units may not operate without an automatic voltage regulator without approval by the Transmission Operator.

**B.11 Low Voltage Ride-Through Capability**

Per FERC Order no. 693 paragraph 1787, all generation connecting to the transmission network must be able to ride through disturbances that depress system voltage as described in FERC Order 661-A. The Customer must communicate the low voltage ride-through capability of the Generating Facility, as described by a voltage magnitude for a certain duration (see example in table below).

**Table A-2: Example of Low Voltage Ride-Through Capability Description**

| <b>Generator terminal voltage (p.u.)</b> | <b>Time Delay for Trip</b> |
|--|----------------------------|
| $V > 1.15$                               | 1.0 seconds                |
| $0.90 < V < 1.15$                        | Continuous operation       |
| $0.85 < V < 0.90$                        | 15.0 seconds               |
| $0.80 < V < 0.85$                        | 1.00 seconds               |
| $0.15 < V < 0.80$                        | 0.50 seconds               |
| $V < 0.15$                               | 0.25 seconds               |